

FUZZY BELIEF NETS

KAI F. GOEBEL

*Information Technology Lab, General Electric Corporate Research & Development
K1-5C4A, One Research Circle, Niskayuna, NY 12309, USA*

ALICE M. AGOGINO

*Department of Mechanical Engineering
University of California at Berkeley, Berkeley, CA 94720-1740, USA*

Received (April 6, 1998)

Revised (December 20, 1999)

This paper introduces fuzzy belief nets (FBN). The ability to invert arcs between nodes is key to solving belief nets. The inversion is accomplished by defining closeness measures which allow diagnostic reasoning from observed symptoms to cause of failures. The closeness measures are motivated by a Lukasiewicz operator which takes into account the distance from an observed symptom set to the modeled symptom set for all failure combinations. Hypothesized failures are then ranked according to maximum closeness measure and minimum cover, i.e., number of faults. Within the realm of fuzzy logic we show the graphical representation and solution of fuzzy belief nets.

Keywords: Diagnosis, Reasoning under Uncertainty, Causal Diagrams, Belief Nets

1. Introduction

Belief nets and influence diagrams were developed to facilitate automating the modeling of complex decision problems involving uncertainty using a compact graphical framework for representing the interrelationships between the variables involved in the problem under consideration.^{1,2,3,4} They can be used to solve decision and probabilistic inference problems. At the topological level an influence diagram is an acyclic directed network with nodes representing variables critical to the problem and the arcs representing their interrelationships. Formal calculi have been developed for deterministic functions and probabilistic relationships based on either Bayesian or fuzzy probabilities. At the topological level the structure of complex decision problems can be extracted from domain experts which is encoded in 1.) decision nodes (in which the variable is under the control of the decision-maker); 2.) state nodes (which correspond to the uncertain quantities not under the control of the decision-maker); and 3.) a single value node (in which the utility function is specified for a decision problem. Arcs going into state nodes represent conditional influence and can be reversed through legal topological transformations on the diagram according to Bayes' rule – providing a cycle is not introduced. Jain and Agogino developed Bayesian fuzzy probabilities and arithmetic operations that are consistent with Bayes' rule and retain closure of the required properties.⁵ The arithmetic operations are those necessary for Bayesian analysis: addition,

multiplication, division, and expectation of joint and marginal discrete probability distributions. Application of the arithmetic operations results in a solution in which the mean of the fuzzy function is equivalent to the point estimate obtained by using conventional Bayesian probability. The resulting fuzzy function around the mean can be used for stochastic sensitivity analysis; its interpretation depends on the application. They also explored the concept of a fuzzy probabilistic influence diagram as a means of representing and manipulating fuzzy probabilities in inference and decision problems. Outside the probabilistic realm, one of the main problems in solving diagnostic queries with belief nets and influence diagrams is the inversion of arcs because there are usually several symptoms which fit several failures. While “forward” reasoning from cause to effect is generally understood and various means exist to solve this problem using deterministic, probabilistic, or fuzzy means, solutions developed so far for “backward” reasoning from symptom to cause have various shortcomings. Sanchez first investigated the solution to the inversion of the fuzzy relation $A \circ R = B$ (with fault vector A, symptom vector B, and relational matrix R) which allowed him to find a least upper bound with the help of the operator “ α ”.⁶ Mizumoto and Zimmermann approached the inversion problem by introducing several appropriate relational operators which allowed to express the inversion as a modus tollens of the form $B'_x = A' \circ R_x$.⁷ Fuzzy fault trees were used by Gmytrasiewicz et al.⁸ and Ulieru.⁹ The latter manually created a diagnostic relevant network with the help of experiential knowledge and first principles. Using fuzzy modus tollens for validation, the pair with highest similarity for both methods is found as the solution. Engemann et al. proposed a methodology for decision making under uncertainty, integrating ordered weighted averaging aggregation operators and Dempster-Shafer belief structure which is used as a framework for representing information a decision maker has regarding relevant events.¹⁰ Hisdal described conditional possibility extended by Dubois and Prade to a possibilistic version of Bayes' theorem.^{11,12} A similar solution is suggested by Kosko, who uses fuzzy supersethood.¹³ This approach in turn is used by Dalton applying parsimonious covering theory to fuzzy logic,^{14,15} using a similarity measure assuming crisp symptoms. Shortcomings of these approaches are that they do not always provide a solution and if there is one it may be bounded by a range too wide to be useful for decision making, or inadequacies due to the nature of the operators used. In the approach introduced here, knowledge is taken from fuzzy cause-effect relationships modeled via causal diagrams. “Backward” reasoning becomes possible with the introduction of a proper fuzzy measure. The power of fuzzy belief nets not only allows modeling of fuzzy rules but provides a way to incorporate the degree to which a symptom is observed into the reasoning apparatus. It is not necessary to evaluate the probability of an event or wait until a threshold has been passed. In addition, it provides a way to represent uncertainty for instances where the use of fuzzy logic is preferred over other tools dealing with uncertainty and a formal way to backward chain. The use of linguistic rules in combination with fuzzy belief nets provides a transparent and straightforward way to represent knowledge.

2. Method for Inversion of Fuzzy Relation

To achieve the inversion of the cause-effect relation, a fuzzy measure is introduced which will assign a degree of similarity with each possible failure. Both sudden and gradual malfunctions can be treated in a real-time fashion. We build on the notion of abduction using a fuzzy scheme. Inference in abduction looks at a general rule and a specific result. Out of a large number of hypothetical solutions one specific case is chosen to be most

likely. In binary logic both rule and symptom are evaluated with respect to their truth and only when both are found to be true the rule can be hypothesized. In many valued logic, both rules and results are always true to some extent and therefore both rules can be hypothesized to some degree. It is therefore necessary to come up with a way to find a method which identifies the most likely hypothesis. Such a scheme will be introduced here. This scheme makes use of fuzzy causal diagrams. To begin, failure-symptom relationships are expressed in fuzzy causal diagrams as displayed in Fig. 1 (to avoid overcrowding of the graph, links with strength zero were omitted) where the f_n represent the failures and the s_m stand for the symptoms. This means that a fault f_n causes a number of symptoms s_m to occur to some extent. That is, some symptoms are produced more strongly than others. Other faults may cause the same symptoms but with a different degree of strength.

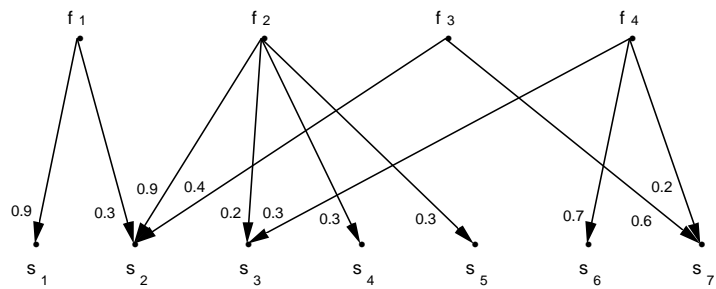

Fig. 1. Fuzzy causal diagram

The fuzzy connection between fault and symptom can be encoded in a fault-symptom matrix. With the assumption that several faults will cause the maximum value of both individual symptoms and that there are no mutually exclusive failures, modeling of multiple concurrent faults can be achieved as seen in

Table 1. Here, all possible failure combinations are enumerated from no failure at all to the case where all failures occur simultaneously.

A fuzzy measure of closeness is proposed which is motivated by the notion of subsethood and its Lukasiewicz equivalent.^{13,14} We distinguish two cases: faults can occur in either a crisp manner (power outage, electrical short, etc.) or in a soft manner (gradual failure, increasing bias, dependency of performance on temperature, etc.). These two situations are accounted for with three related closeness measures introduced below. After some faults have been hypothesized, it is the goal to decide which of all possible solutions is the most likely one. Therefore, a ranking scheme is necessary which will discard the less likely hypotheses and rank the most plausible one on top. In case two fault combinations are equally likely, the set of failures with minimal cardinality will be chosen in accordance with parsimonious covering theory.

Table 1. Fault-symptom matrix

s_1	s_2	s_3	s_4	s_5	s_6	s_7	f_1	f_2	f_3	f_4
0	0	0	0	0	0	0	0	0	0	0
0	0	.3	0	0	.7	.2	0	0	0	1
0	.4	0	0	0	0	.6	0	0	1	0
0	.4	.3	0	0	.7	.6	0	0	1	1
0	.9	.2	.3	.3	0	0	0	1	0	0
0	.9	.3	.3	.3	.7	.2	0	1	0	1
0	.9	.2	.3	.3	0	.6	0	1	1	0
0	.9	.3	.3	.3	.7	.6	0	1	1	1
.9	.3	0	0	0	0	0	1	0	0	0
.9	.3	.3	0	0	.7	.2	1	0	0	1
.9	.4	0	0	0	0	.6	1	0	1	0
.9	.4	.3	0	0	.7	.6	1	0	1	1
.9	.9	.2	.3	.3	0	0	1	1	0	0
.9	.9	.3	.3	.3	.7	.2	1	1	0	1
.9	.9	.2	.3	.3	0	.6	1	1	1	0
.9	.9	.3	.3	.3	.7	.6	1	1	1	1

2.1 Crisp failures

If faults are known to be crisp, then the distance of the measured symptom to the symptom set for the closest fault will be determined. Evidence $S^+(F_1)$ is aggregated by summing up the Euclidean distance of the observation to the modeled symptom set of a particular fault combination in the symptom-failure space as shown for a two-dimensional case with two symptoms and four faults in Fig. 2. The missing fourth fault is the \emptyset -fault which is assumed to be at the origin. $S(F_1)$ can be interpreted as the fault strength for a fault combination F_1 . $S(F_1)$ is expressed as the normed distance from the origin to the modeled fault which is always 1 in the crisp case.

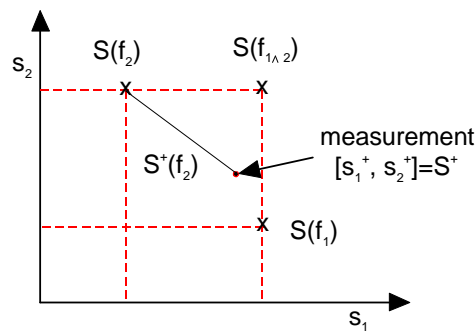

Fig. 2. Aggregation of Evidence in the symptom-failure space for crisp faults and fuzzy symptoms

The closeness measure γ_c for the crisp case is of the form

$$\gamma_c(S(F_I), S^+) = 1 - \min(1, 1 - S(F_I) + S^+(F_I)) \quad (1)$$

where

$S(F_I)$ is the particular fault strength for the modeled fault combination F_I . It is the normed distance of the modeled fault to the origin. (Note: $S(F_I) = 1$ for crisp faults).

$$S^+(F_I) = \sqrt{\sum_{i=1}^n (s_i(F_I) - s_i^+)^2}$$

n is the number of observations

This measure allows the occurrence of observations which are larger than the maximum symptoms which are defined for any fault. This provides some flexibility in modeling the faults and acknowledges that there may be modeling errors. Some observations may be larger than symptoms originally predicted but they should be assigned to a fault nonetheless. This situation is depicted in Fig. 3. Here two faults are modeled where fault f_1 causes both symptoms that are also caused by fault f_2 . However, the modeled symptoms for f_1 are smaller. Although the measurements are larger than the two symptoms for fault f_1 , the closeness measure will still assign fault f_1 a higher numerical value than fault f_2 because the measurement is closer to fault f_1 than to fault f_2 .

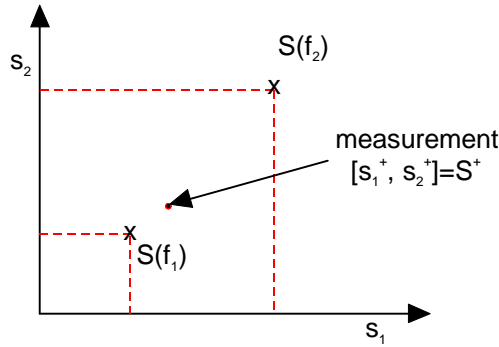

Fig. 3. Measurement larger than symptoms modeled

The measure obtained through $\gamma_c(S(F_I), S^+)$ is a “dissemblance” measure and meets requirements of symmetry and anti-reflexivity, but not of co-transitivity.¹⁶

2.2 Gradual failures

For gradual failures, a means is provided which takes into account the distance of the observation to the closest symptom set for a fault as well as to what degree the fault may occur. This necessitates the measurement of two quantities: one is the closest distance

from the observation to the fault line. The fault line denotes the line on which all gradual instances of one particular fault are assumed to lie. It starts at the origin and is monotonically increasing. The other quantity involves measurement $S_n(F_1)$ between origin and intersection S_R^+ of failure line and closest connection $S_d^+(F_1)$ from the failure line to observation S^+ . This situation is depicted in Fig. 4.

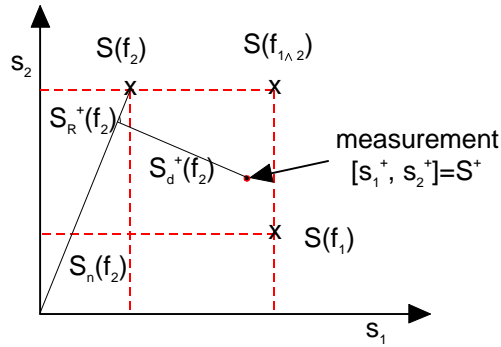

Fig. 4. Aggregation of evidence in the symptom-failure space for gradual faults and symptoms

The resulting measure is of the form

$$\gamma_s(S(F_I), S^+) = 1 - \min(1, 1 - S_n(F_I) + S_d^+(F_I)) \quad (2)$$

where

$S(F_I)$ is the fault strength for failure F_I

S^+ are the observed symptoms

$S_n(F_I)$ is the degree to which the failure occurred expressed by the length of the failure line to the intersection with the closest distance to the measurement, normed by the overall length of the failure. We distinguish the case where $S_R^+(F_I)$ is larger than $S(F_I)$ and the case where $S_R^+(F_I)$ is smaller than $S(F_I)$.

Due to norming problems for zero length vectors $S(F_I) = 0$ that case is defined separately.

$$\gamma_s(S(F_I), S^+) = \begin{cases} 1 - \min \left(1, 1 - \frac{\left(\sum_{i=1}^n (s_i(F_I))^2 \right)^{\frac{1}{2}}}{\left(\sum_{i=1}^n (s_{R_i}^+(F_I))^2 \right)^{\frac{1}{2}}} + \left(\sum_{i=1}^n (s_{R_i}^+(F_I) - s_i^+)^2 \right)^{\frac{1}{2}} \right) & \text{for } S(F_I) > S_R^+(F_I), S(F_I) \neq 0 \\ 1 - \min \left(1, 1 - \frac{\left(\sum_{i=1}^n (s_{R_i}^+(F_I))^2 \right)^{\frac{1}{2}}}{\left(\sum_{i=1}^n (s_i(F_I))^2 \right)^{\frac{1}{2}}} + \left(\sum_{i=1}^n (s_{R_i}^+(F_I) - s_i^+)^2 \right)^{\frac{1}{2}} \right) & \text{for } S(F_I) \leq S_R^+(F_I), S(F_I) \neq 0 \\ 0 & \text{for } S(F_I) = 0, S^+ \neq 0 \\ 1 & \text{for } S(F_I) = 0, S^+ = 0 \end{cases} \quad (3)$$

Details of the derivation and vector algebra used to compute the distance can be found in Goebel.¹⁷ γ_s is also a dissemblance measure. It meets requirements of symmetry and anti-reflexivity and not of co-transitivity. We refer to this measure as a measure of closeness.

The diagnostic distribution around the modeled failure extends to the entire range for a failure between zero and one in contrast to the crisp distribution. For ease of computation, the fault model can be assumed to be a straight line, although it could be of any other shape as well. In the latter case, the computation for distance would have to be adjusted accordingly.

So far, decisions have been made only when there was one fault. We will now outline the case when several faults occupy the same symptom space. To illustrate, the following graphs (Fig. 5 through Fig. 6) show the maximum fault profile for three faults (excluding the \emptyset -fault) in a two-dimensional symptom space. Although faults are usually modeled with more distinctive symptoms, the graphs give a good idea of how the diagnosis operates. The faults were modeled as $s_1 = \begin{bmatrix} 0.8 \\ 0.2 \end{bmatrix}$, $s_2 = \begin{bmatrix} 0.3 \\ 0.7 \end{bmatrix}$, and $s_3 = \begin{bmatrix} 0.9 \\ 0.9 \end{bmatrix}$. Fig. 5 shows the maximum fault profile for γ_c . The maximum failure surface is smooth and

faults are seen to be centered around their modeled place in space. The valleys between the maxima show where the fault would be diagnosed equally likely for either of two faults. Fig. 6 shows the maximum failure profile for soft γ_s . The contours are closer indicating steeper gradients on the surface.

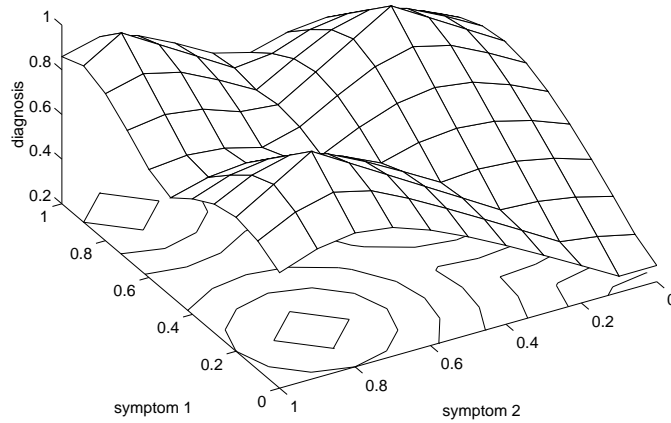

Fig. 5. Modeling of three faults with two symptoms using γ_c

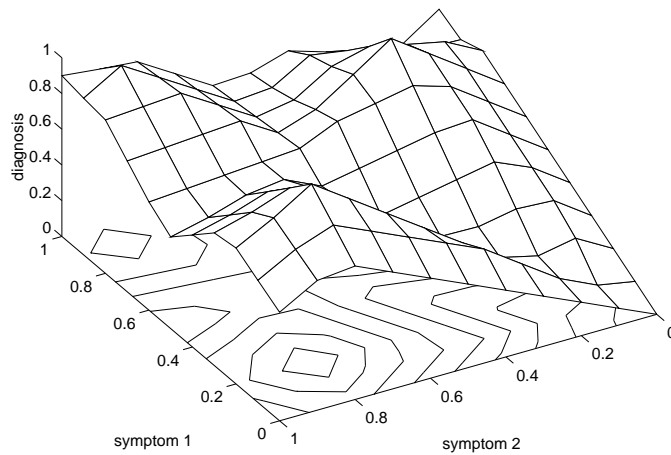

Fig. 6. Modeling of three faults with two symptoms using γ_s

3. Graphical Representation of Fuzzy Belief Nets

In the previous sections we discussed the tools necessary for inverting a fuzzy relation (arc reversal in FBN). This section introduces notation for operations on the topological level of the FBN. Specifically, we explain the types of nodes involved and how to deal

with different connections which are expressed through AND/OR linguistically in the antecedents and consequents of rules. Each introduced operator is followed by a practical example. The section concludes with a more complex illustrative example to demonstrate how the different pieces can be put together.

3.1. Notation

The graphical representation of fuzzy belief nets consists of nodes and arcs. The nodes are either state nodes which correspond to the uncertain quantities which are not under direct control or control nodes where the variable is under direct control. As in probabilistic belief nets the state nodes are shaped circular.¹⁸ Arcs between nodes represent the (fuzzy) causal relations from one state to the other as displayed in Fig. 7.



Fig. 7. Fuzzy causal relation represented by arc between two state nodes

Three types of state nodes are used for applications in diagnostic reasoning: 1.) sensor nodes which can be directly observed; 2.) failure nodes which represent the physical components in the system which are subject to diagnostic search. Failure nodes are the cause for symptoms observed;¹⁷ 3.) finally, intermediate nodes which are useful for modeling the belief net but are not the goal or conditioning nodes. Rather, they often represent intangibles in the problem which are not directly measured. Fig. 8 shows the three types of nodes.

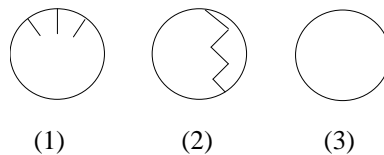

Fig. 8. State nodes: (1) sensor, (2) failure, (3) intermediate

The inference engine for diagnosis starts from the observation of measurements obtained from sensors and chains through the belief net to obtain degrees of truth for failures and to find the causes for failures. There are several basic operations which are used with fuzzy belief nets. These operations originate in the interpretation of the arc which is understood as a fuzzy rule of the form IF fault A THEN symptom B. Fig. 9 shows the model for this basic rule.



Fig. 9. Fuzzy rule: IF A THEN B

As an example the rule will be used that the temperature of a system rises a lot when the valve gets stuck. This rise is modeled to cause the associated symptom to a degree 0.7. The matrix representation of this rule is expressed in Table 2.

Table 2. Matrix representation of rule: IF valve gets stuck THEN temperature rise large

s_B	f_A
0	0
0.7	1

Assuming an observation of “temperature rise large” of 0.6 and using the closeness measure γ_C , the result is computed to be $\gamma_C=0.9$.

3.1.1. AND antecedent

More complex rules involve the use of “AND” and “OR” operators which implies there are two or more antecedents or consequents. Here, only combinations of two antecedents or consequents with “AND” and “OR” operators are shown. The extension to cases involving more than two operands is straight forward. The rule “IF A AND B THEN C” is displayed using the graphical representation in Fig. 10. Note the AND-operator displayed next to node C.

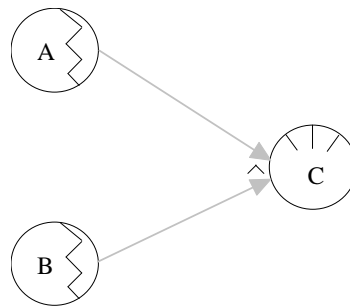

Fig. 10. Fuzzy rule: IF A AND B THEN C

For calculation purposes, this rule is reduced to the following representation (Fig. 11):



Fig. 11. Alternative representation for rule: IF A AND B THEN C

The two arcs are replaced by one single arc which carries the weight of the minimum weight of the two arcs. The diagnosis has the same value for both antecedents A and B. As a consequence, the rule “IF valve stuck AND bypass clogged THEN temperature rise large” uses a similar matrix representation as used in

Table 1.

3.1.2. OR antecedent

The rule “IF A OR B THEN C” is represented graphically as displayed in Fig. 12. Note the OR-operator displayed next to node C.

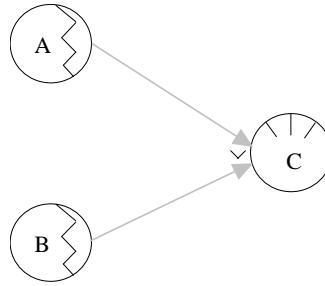

Fig. 12. Fuzzy rule: IF A OR B THEN C

This rule is equivalent to the three representations as displayed in Fig. 13.

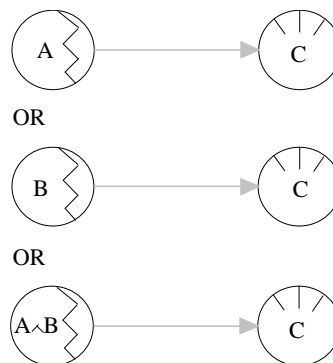

Fig. 13. Alternative representation for rule: IF A OR B THEN C

The matrix representation for rule “IF valve stuck OR pipe leaks THEN pressure drops is medium” is shown in Table 3.

Table 3. Matrix representation of rule: IF valve gets stuck OR pipe leaks THEN pressure drop medium

s_C	f_A	f_B
0	0	0
0.8	0	1
0.7	1	0
0.8	1	1

The closeness measure will be calculated for each case and the maximum closeness measure is used as the most likely candidate. Notice that in this model the failure “A and B” has higher degree of complexity and will not be considered with the presumption of minimum cardinality for the solution because each solution based on one sensor observation will render equal results for A and “A AND B”. For an observation of 0.6, the closeness measure is $\gamma_c=0.9$.

3.1.3. AND consequent

The rule IF A THEN B AND C is displayed with the graphical representation in Fig. 14 where the \wedge -operator is shown next to node A.

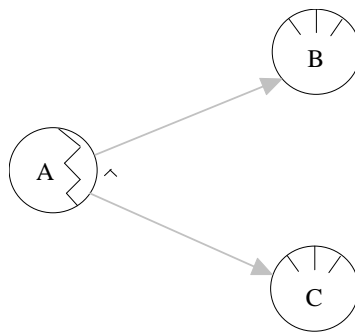

Fig. 14. Fuzzy rule: IF A THEN B AND C

The rule “IF valve stuck THEN temperature rise large AND pressure drop medium” can be represented in matrix notation as shown in Table 4.

Table 4. Matrix representation of rule: IF valve gets stuck THEN temperature rises AND pressure drops

s_B	s_C	f_A
0	0	0
0.6	0.3	1

With an observation of $\begin{bmatrix} 0.5 \\ 0.4 \end{bmatrix}$, the closeness measure for this example is $\gamma_c=0.8586$.

3.1.4. OR consequent

For the rule “IF A THEN B OR C” the graphical representation is shown in Fig. 15 where the \vee -operator is displayed next to node A.

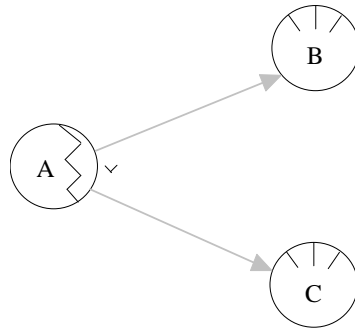

Fig. 15. Fuzzy rule: IF A THEN B OR C

This rule can be decomposed into three cases as displayed in Fig. 16.

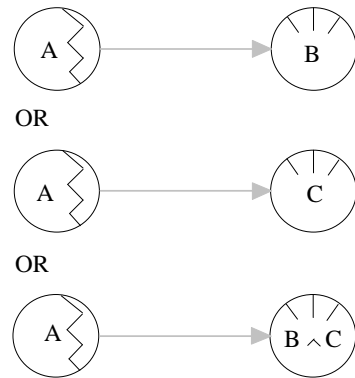

Fig. 16. Alternative representation for rule: IF A THEN B OR C

The matrix representation for rule “IF valve stuck THEN temperature rise large OR pressure drop medium” is shown in Table 8.

Table 5. Matrix representation of rule: IF valve gets stuck THEN temperature rise large OR pressure drop medium

s_B	s_C	f_A
0	0	0
0.6	0	1
0	0.3	1
0.6	0.3	1

3.2. Illustrative example

The same relations can be used to propagate the evidence for arcs connecting any combination of sensor nodes, failure nodes, source nodes, and intermediate nodes. To explain the concept further, an illustrative example will be used which has more complex connections. Consider the network as displayed in Fig. 17 where

- (i) A is the root cause (failure) that there are particles in the flow
- (ii) B is the root cause (failure) that the fluid is corrosive
- (iii) C is the state that the valve is stuck
- (iv) D is the state that the pipe leaks
- (v) E is the sensor observation that the temperature rises a lot
- (vi) F is the sensor observation that the pressure drop is medium
- (vii) G is the sensor observation that the temperature is down slightly

The numbers next to the arc are the membership values for the rule represented by the arc. The rules are:

- IF there are particles in the flow THEN the valve is stuck
- IF the fluid is corrosive THEN the valve gets stuck OR the pipe leaks
- IF the valve is stuck THEN the temperature rises a lot AND the pressure goes down medium
- IF the pipe leaks THEN the pressure goes down medium AND the temperature goes down slightly

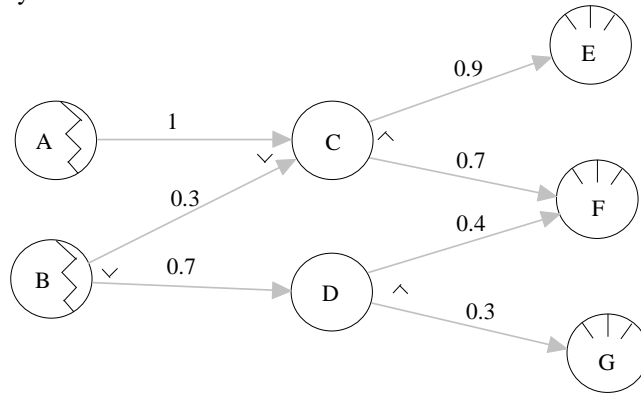

Fig. 17. Fuzzy belief net: illustrative example

Let the observation for the sensors be $\begin{bmatrix} s_E \\ s_F \\ s_G \end{bmatrix} = \begin{bmatrix} 0.8 \\ 0.4 \\ 0.1 \end{bmatrix}$. Using the rules established

earlier, the first step in backpropagating the evidence results in the calculation of the closeness for intermediate nodes C and D. Both nodes have an AND connection to the symptoms observed. The closeness measure for node C is calculated as $\gamma_c=0.6838$, the closeness measure for node D is $\gamma_c=0.8$, and the closeness measure for event C AND D is $\gamma_c=0.6258$. The operations are illustrated in Fig. 18.

s_E	s_F	f_C	γ_c
0	0	0	0.1056
0.9	0.7	1	0.6838

s_E	s_F	s_G	$f_{C \wedge D}$	γ_c
0	0	0	0	0.1
0.9	0.7	0.3	1	0.6258

s_E	s_F	f_D	γ_c
0	0	0	0.5877
0.4	0.3	1	0.8

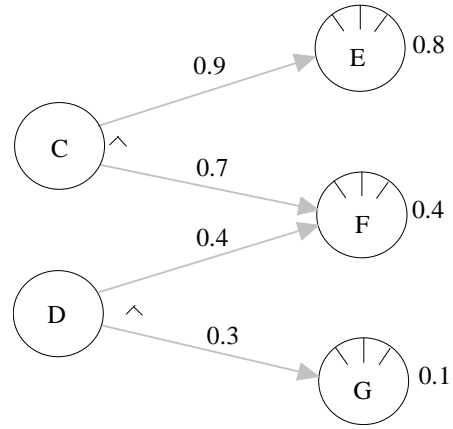

Fig. 18. Operations to solve fuzzy influence diagram; example case

To find the failure root, the highest closeness measure is taken while the others are disregarded. In this case, node D ($\gamma_c=0.8$) is chosen. Since only one failure node is modeled for the event under consideration, the task is trivial and reduces to failure B as shown in Fig. 19.

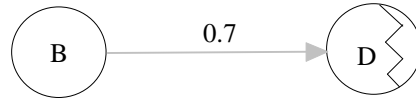

Fig. 19. Source B is found as cause for the failure; example case

Had the observation been such that node C was diagnosed, e.g. $\begin{bmatrix} s_E \\ s_F \\ s_G \end{bmatrix} = \begin{bmatrix} 0.8 \\ 0.8 \\ 0.1 \end{bmatrix}$, the

closeness measure for nodes C, D, and $C \wedge D$ would be $\gamma_c(f_C) = 0.8586$, $\gamma_c(f_D) = 0.5528$, and $\gamma_c(f_{C \wedge D}) = 0.7551$, respectively. In that case, propagation of evidence from the intermediate nodes to the failure nodes is performed on both possible branches (as shown in Fig. 22) to result in $\gamma_c(S_A) = 0.8586$, $\gamma_c(S_B) = 0.4414$, and $\gamma_c(S_{A \wedge B}) = 0.4238$. The interpretation of these results is that failure A is more likely than failure B and the combined failure $A \wedge B$. A remedial plan has to move according to these results.

s_E	s_F	s_G	f_C	f_D	γ_c
0	0	0	0	0	0.1414
--	0.4	0.3	0	1	0.8586
0.9	0.7	--	1	0	0.4414
0.9	0.7	0.3	1	1	0.4238

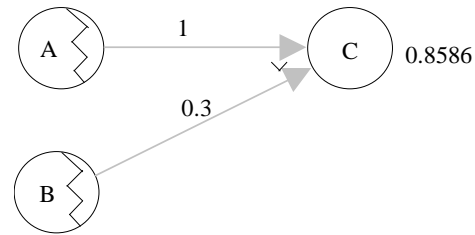

Fig. 20. Failure C is found as the failure; modified example case

4. Conclusions

The proposed approach introduces fuzzy belief nets and shows how the arc between nodes can be inverted using closeness measures γ_c and γ_s . The calculation of the closeness measure uses distance metrics from the observed symptom set to the symptom set for a failure combination and – in the case of soft failures – distance measures to the failure line. The closeness measure for soft failures allows to determine to which degree a failure occurs. It calculates the distance to the failure line as a measure for the degree of the symptom and the distance from origin to intersection with shortest distance, normed by the overall length of the failure line, as a measure for the strength of the failure. Advantages of this approach are that it overcomes several shortcomings of previous fuzzy approaches where solutions are not always given, have an unacceptable large upper and lower bound, or are accomplished by manually reverting rules. Some insufficiencies of threshold driven diagnosis are eliminated because the approach avoids assumptions of failure independence and of relative frequency of disorder occurrence. Links in the belief net are represented as causal strengths for failure-symptom relations similar to the Bayesian approach.

Additional expert knowledge about the behavior of multiple fault-symptom relations can be incorporated into the system model which may result in placement of combined faults at locations other than the maxima of their symptoms when the failures are (partially) canceling their symptoms or when the straight line model for the failure behavior is known to be incorrect.

In contrast to the Bayesian approach, this approach avoids assumptions of relative frequency of disorder occurrence. Similar is that the links in the causal network represent causal strengths for failure-symptom relations. The potentially large number of possible covers for all possible combinations of symptoms is reduced by a ranking scheme which prunes the solution space between levels. While this is a first step at representing FBNs and reverting arcs, future work will explore automation issues. Likewise the issue of combinatorial complexity is subject to more research. Possible extensions of this work also include the development of fuzzy influence diagrams using a fuzzy utility measure.

References

1. A.C. Miller III, M.W. Merkhofer, R.A. Howard, J. E. Matheson, and T.R. Rice, "Development of Automated Aids for Decision Analysis", prepared for the Defense Advanced Research Projects Agency (DARPA), Menlo Park, California, SRI International, 1976.
2. S. M. Olmstead, "On Representing and Solving Decision Problems", PhD thesis, Department of Engineering-Economic Systems, Stanford University, 1984.
3. R.D. Shachter, "Automating Probabilistic Inference", Presented at the Nineteenth Actuarial Research Conference - 1984, Credibility Theory and Bayesian Approximation Methods, University of California, Berkeley, (1984).
4. Agogino, A., and A. Rege, "IDES: Influence Diagram Based Expert System", *Mathematical Modeling*, **8**, (1987).
5. Jain, P., and Agogino, A., "Stochastic Sensitivity Analysis using Fuzzy Influence Diagrams", *Proceedings of the Fourth AAAI Workshop on Uncertainty in Artificial Intelligence*, Revised version published in *Uncertainty in Artificial Intelligence 4*, eds., R.D. Shachter, T.S. Levitt, L.N. Kanal, J.F. Lemmer; Elsevier Science Publishers V.V., North-Holland Press, 1990.
6. E. Sanchez, "Resolution of Composite Fuzzy Equations", *Inf. Control*, **30**, (1976).
7. M. Mizumoto and H.-J. Zimmermann, "Comparison of Fuzzy Reasoning Methods", *Fuzzy Sets and Systems*, **8**, No. 3, (1982).
8. P. Gmytrasiewicz, J.A. Hassberger, and J.C. Lee, "Fault Tree Based Diagnostics Using Fuzzy Logic", *IEEE Transactions on Pattern Analysis and Machine Intelligence*, **12**, No. 11, (1990).
9. M. Ulieru, "Diagnosis by Approximate Reasoning on Fuzzy Fault Trees", *Proceedings of the third IEEE Conference on Fuzzy Systems*, *IEEE World Congress in Computational Intelligence*, Orlando, FL, (1994).
10. K.J. Engemann, H.E. Miller, R.R. Yager, "Decision Making with Belief Structures: An Application in Risk Management", *International Journal of Uncertainty, Fuzziness and Knowledge-Based Systems*, **4**, No.1, (1996).
11. E. Hisdal, "Conditional Possibilities, Independence and Noninteraction", *Fuzzy Sets and Systems*, **1**, No.1, (1978).
12. D. Dubois, and H. Prade, "Possibilistic Abduction", *IPMU '92 - Advanced Methods in Artificial Intelligence*, Proceedings of the 4th International Conference in Information Processing and Management of Uncertainty in Knowledge-Based Systems, Palma de Mallorca, Spain, (1992).
13. B. Kosko, "Fuzzy Entropy and Conditioning", *Information Sciences*, **40**, No. 2, (1986).
14. Dalton, R., "Towards a Theory of Fuzzy Causality for Diagnosis", *Information Sciences*, Vol. 80, 1993.
15. Y. Peng, and J.A. Reggia, *Abductive Inference Models for Diagnostic Problem-Solving*, (Springer-Verlag, New York, 1990).
16. A. Kaufmann, *Introduction to the Theory of Fuzzy Subsets*, (Academic Press, New York, 1971).
17. K. Goebel, "Management of Uncertainty in Sensor Validation, Sensor Fusion, and Diagnosis of Mechanical Systems Using Means from Soft Computing", Ph.D. Thesis, University of California at Berkeley, 1996.
18. A.M. Agogino, S. Srinivas, and K. Schneider, "Multiple Sensor Expert System for Diagnostic Reasoning, Monitoring, and Control of Mechanical Systems," *Mechanical Systems and Signal Processing*, **2** (2), (1988), pp. 165-185.