

# Towards Fuzzy Belief Nets

Kai Goebel<sup>1\*</sup> & Alice Agogino<sup>2</sup>

<sup>1</sup>Information Technology Lab, General Electric Corporate Research and Development  
K1-5C4A, One Research Circle, Niskayuna, NY 12309, USA  
goebelk@crd.ge.com

<sup>2</sup>Department of Mechanical Engineering  
University of California at Berkeley, Berkeley, CA 94720-1740  
agogino@euler.me.berkeley.edu

## Abstract

In this paper we investigate how the observation of symptoms which do not completely match a modeled fault can be used to find the most likely fault – and the degree to which this fault occurs. We start out by setting up fuzzy causal diagrams and then show how with the use of a proper operator the arcs of the causal diagram can be reversed. We introduce a graphical representation for fuzzy belief nets (FBN) and show how both AND and OR connected antecedents and consequents of rules can be accommodated. The paper concludes with an illustrative diagnostic example.

## Introduction

While “forward” reasoning from cause to effect is generally understood and various means exist to solve this problem using deterministic, probabilistic, or fuzzy means, solutions developed so far for “backward” reasoning from symptom to cause have various shortcomings. In the fuzzy domain Sanchez (1976) first investigated the solution to the inversion of the fuzzy relation  $A \circ R = B$  (with fault vector  $A$ , symptom vector  $B$ , and relational matrix  $R$ ) which allowed him to find a least upper bound with the help of an operator “ $a$ ”. Mizumoto and Zimmermann (1982) approached the inversion problem by introducing several appropriate relational operators which allowed to express the inversion as a modus tollens of the form  $B'_x = A' \circ R_x$ . Fuzzy fault trees were used by Gmytrasiewicz et al. (1990) and Ulieru (1994). The latter manually created a diagnostic relevant network with the help of experiential knowledge and first principles. Using fuzzy modus tollens for validation, the pair with highest similarity for both methods is found as the solution. Engemann et al. proposed a methodology for decision making under uncertainty, integrating ordered weighted averaging aggregation operators and Dempster-Shafer belief structure which is used as a framework for representing information a decision maker has regarding relevant events (1996). Hisdal (1978) described conditional possibility extended by Dubois and Prade to a possibilistic version of Bayes'

theorem (1992). A similar solution is suggested by Kosko, who uses fuzzy supersethood (1986). This approach in turn is used by Dalton (1993) applying parsimonious covering theory (Peng and Reggia, 1990) to fuzzy logic, the former using a similarity measure assuming crisp symptoms. Shortcomings of these approaches are that they do not always provide a solution and if there is one it may be bounded by a range too wide to be useful for decision making, or inadequacies due to the nature of the operators used. In the approach introduced here, knowledge is taken from fuzzy cause-effect relationships modeled via causal diagrams. “Backward” reasoning becomes possible with the introduction of a proper fuzzy measure. We then show how this system can be understood as a step towards fuzzy belief nets. The method provides a way to incorporate the degree to which a symptom is observed into the reasoning apparatus.

## Background on Probabilistic Belief Nets

Probabilistic belief nets and influence diagrams were developed to facilitate automating the modeling of complex decision problems involving uncertainty using a compact graphical framework for representing the interrelationships between the variables involved in the problem under consideration (Miller et al., 1976; Olmstead, 1984; Shachter, 1984; Agogino and A. Rege, 1987). They can be used to solve decision and probabilistic inference problems. At the topological level an influence diagram is an acyclic directed network with nodes representing variables critical to the problem and the arcs representing their interrelationships. Arcs going into nodes represent conditional influence and can be reversed through legal topological transformations on the diagram according to Bayes' rule. Jain and Agogino developed Bayesian fuzzy probabilities and arithmetic operations that are consistent with Bayes' rule and retain closure of the required properties (Jain and Agogino, 1990). Application of the arithmetic operations results in a solution in which the mean of the fuzzy function is equivalent to the point estimate obtained by using conventional Bayesian probability. The resulting fuzzy function around the mean can be used for stochastic sensitivity analysis; its interpretation depends on the application.

---

\*The author was with UC Berkeley at the time of this research

## Method for Inversion of Fuzzy Relation

To achieve the inversion of the cause-effect relation, a fuzzy measure is introduced which will assign a degree of similarity with each possible failure. Both sudden and gradual malfunctions can be treated using slightly different operators. We build on the notion of abduction using a fuzzy scheme. Inference in abduction looks at a general rule and a specific result. Out of a large number of hypothetical solutions one specific case is chosen to be most likely. In binary logic both rule and symptom are evaluated with respect to their truth and only when both are found to be true the rule can be hypothesized. In many valued logic, both rules and results are always true to some extent and therefore all rules can be hypothesized to some degree. Therefore, we have to come up with a way to find a method which identifies the most likely hypothesis.

To begin, failure-symptom relationships are expressed in fuzzy causal diagrams as displayed in Fig. 1 (to avoid overcrowding of the graph, links with strength zero were omitted) where the  $f_n$  represent the failures and the  $s_m$  stand for the symptoms. This means that a fault  $f_n$  causes a number of symptoms  $s_m$  to occur to some extent. That is, some symptoms are produced more strongly than others. Other faults may cause the same symptoms but with a different degree of strength.

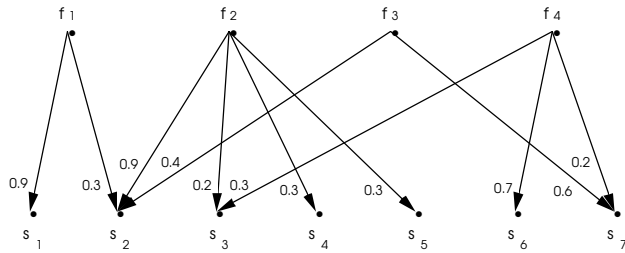

Fig. 1: Fuzzy causal diagram

The fuzzy connection between fault and symptom can be encoded in a fault-symptom matrix. With the assumption that several faults will cause the maximum value of both individual symptoms and that there are no mutually exclusive failures, modeling of multiple concurrent faults can be achieved as seen in Table 1. Here, we omit some combinations for brevity.

A fuzzy measure of closeness is proposed which is motivated by the notion of subsethood and its Lukasiewicz equivalent (Kosko, 1990; Dalton, 1993). We distinguish two cases: faults can occur in either a crisp manner (power outage, electrical short, etc.) or in a soft manner (gradual failure, increasing bias, dependency of performance on temperature, etc.). These two situations are accounted for with two related closeness measures introduced below. After some faults have been hypothesized, it is the goal to decide which of all possible solutions is the most likely one. Therefore, a ranking scheme is necessary which will discard the less likely hypotheses and rank the most

plausible one on top. In case two fault combinations are equally likely, the set of failures with minimal cardinality will be chosen in accordance with parsimonious covering theory.

Table 1: Fault-symptom matrix

$s_1$	$s_2$	$s_3$	$s_4$	$s_5$	$s_6$	$s_7$	$f_1$	$f_2$	$f_3$	$f_4$
0	0	0	0	0	0	0	0	0	0	0
0	0	.3	0	0	.7	.2	0	0	0	1
0	.4	0	0	0	0	.6	0	0	1	0
0	.4	.3	0	0	.7	.6	0	0	1	1
0	.9	.2	.3	.3	0	0	0	1	0	0
0	.9	.3	.3	.3	.7	.2	0	1	0	1
0	.9	.2	.3	.3	0	.6	0	1	1	0
0	.9	.3	.3	.3	.7	.6	0	1	1	1
.9	.3	0	0	0	0	0	1	0	0	0
...										
.9	.9	.3	.3	.3	.7	.6	1	1	1	1

## Crisp Failures

If faults are known to be crisp, then the distance of the measured symptom to the symptom set for the closest fault will be determined. Evidence  $S^+(F_1)$  is aggregated by summing up the Euclidean distance of the observation to the modeled symptom set of a particular fault combination in the symptom-failure space as shown for a two-dimensional case (two symptoms and four faults) in Fig. 2. The  $\emptyset$ -fault is assumed to be at the origin.  $S(F_1)$  can be interpreted as the fault strength for a fault combination  $F_1$ .  $S(F_1)$  is expressed as the normed distance from the origin to the modeled fault which is always 1 in the crisp case.

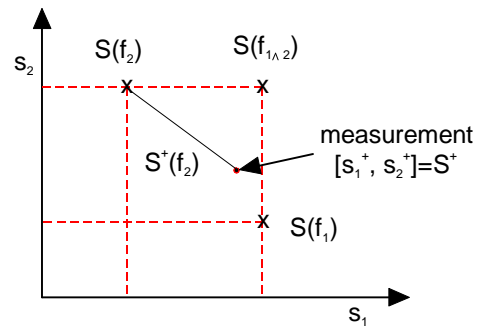

Fig. 2: Aggregation of evidence in the symptom-failure space for crisp faults and fuzzy symptoms

The closeness measure  $\gamma_c$  for the crisp case is of the form

$$\gamma_c(S(F_1), S^+) = 1 - \min(1, 1 - S(F_1) + S^+(F_1))$$

where

$S(F_1)$  is the particular fault strength for the modeled fault combination  $F_1$ . It is the normed distance of the modeled fault to the origin. (Note:  $S(F_1) = 1$  for crisp faults).

$$S^+(F_I) = \sqrt{\sum_{i=1}^n (s_i(F_I) - s_i^+)^2}$$

$n$  is the number of observations

This measure allows the occurrence of observations which are larger than the maximum symptoms which are defined for any fault. This provides some flexibility in modeling the faults and acknowledges that there may be modeling errors. Some observations may be larger than symptoms originally predicted but they should be assigned to a fault nonetheless. This situation is depicted in Fig. 3. Here two faults are modeled where fault  $f_1$  causes both symptoms that are also caused by fault  $f_2$ . However, the modeled symptoms for  $f_1$  are smaller. Although the measurements are larger than the two symptoms for fault  $f_1$ , the closeness measure will still assign fault  $f_1$  a higher numerical value than fault  $f_2$  because the measurement is closer to fault  $f_1$  than to fault  $f_2$ .

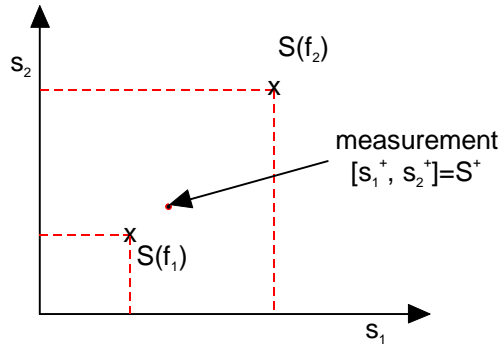

Fig. 3: Measurement larger than symptoms modeled

$\gamma_c(S(F_I), S^+)$  shares an important property for the assignment of truth with abduction. The closeness measure is also not true when the antecedent is false and the consequent is true, the distinctive property of abductive reasoning.

An important concept introduced through allowing symptoms to occur to some degree is the notion of a diagnostic distribution for the failure. This distribution needs to have the value  $\gamma_c = 1$  at the modeled fault and should be smaller further away.

### Gradual Failures

For gradual failures, a means is provided which takes into account the distance of the observation to the closest symptom set for a fault as well as to what degree the fault may occur. This necessitates the measurement of two quantities: one is the closest distance from the observation to the fault line. The fault line denotes the line on which all gradual instances of one particular fault are assumed to lie. It starts at the origin and is monotonically increasing. The other quantity involves measurement  $S_n(F_I)$  between

origin and intersection  $S_R^+$  of failure line and closest connection  $S_d^+(F_I)$  from the failure line to observation  $S^+$ . This situation is depicted in Fig. 4.

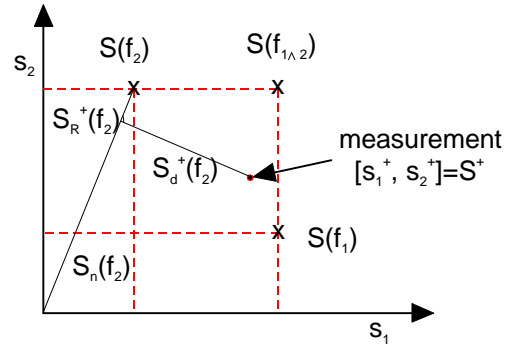

Fig. 4: Aggregation of evidence in the symptom-failure space for gradual faults and symptoms

The resulting measure is of the form

$$\gamma_s(S(F_I), S^+) = 1 - \min(1, 1 - S_n(F_I) + S_d^+(F_I)).$$

or

$$\gamma_s(S(F_I), S^+) = \begin{cases} 1 - \min \left( 1, 1 - \frac{\left( \sum_{i=1}^n (s_i(F_I))^2 \right)^{\frac{1}{2}}}{\left( \sum_{i=1}^n (s_{R_i}^+(F_I))^2 \right)^{\frac{1}{2}}} + \left( \sum_{i=1}^n (s_{R_i}^+(F_I) - s_i^+)^2 \right)^{\frac{1}{2}} \right) & \text{for } S(F_I) > S_R^+(F_I), S(F_I) \neq 0 \\ 1 - \min \left( 1, 1 - \frac{\left( \sum_{i=1}^n (s_{R_i}^+(F_I))^2 \right)^{\frac{1}{2}}}{\left( \sum_{i=1}^n (s_i(F_I))^2 \right)^{\frac{1}{2}}} + \left( \sum_{i=1}^n (s_{R_i}^+(F_I) - s_i^+)^2 \right)^{\frac{1}{2}} \right) & \text{for } S(F_I) \leq S_R^+(F_I), S(F_I) \neq 0 \\ 0 & \text{for } S(F_I) = 0, S^+ \neq 0 \\ 1 & \text{for } S(F_I) = 0, S^+ = 0. \end{cases}$$

where

$S(F_I)$  is the fault strength for failure  $F_I$

$S^+$  are the observed symptoms

$S_n(F_I)$  is the degree to which the failure occurred expressed by the length of the failure line to the intersection with the closest distance to the measurement, normed by the overall length of the failure. We distinguish the case where  $S_R^+(F_I)$  is larger than  $S(F_I)$  and the case

where  $S_R^+(F_1)$  is smaller than  $S(F_1)$ . We define special case  $S(F_1)=0$  for zero length vector separately.

Details of the derivation and vector algebra used to compute the distance can be found in Goebel (1996). We refer to  $\gamma_s$  as a measure of closeness.

The diagnostic distribution around the modeled failure extends to the entire range for a failure between zero and one in contrast to the crisp distribution. For ease of computation, the fault model was here assumed to be a straight line, although it could be of any other shape as well.

We will now outline the case when several faults occupy the same symptom space. To illustrate, the following graph (Fig. 5) shows the maximum fault profile for three faults (excluding the  $\emptyset$ -fault) in a two-dimensional symptom space using  $\gamma_C$ . The faults were modeled as  $s_1 = \begin{bmatrix} 0.8 \\ 0.2 \end{bmatrix}$ ,  $s_2 = \begin{bmatrix} 0.3 \\ 0.7 \end{bmatrix}$ , and  $s_3 = \begin{bmatrix} 0.9 \\ 0.9 \end{bmatrix}$ . The maximum failure surface is smooth and faults are seen to be centered around their modeled place in space. The valleys between the maxima show where the fault would be diagnosed equally likely for either of two faults.

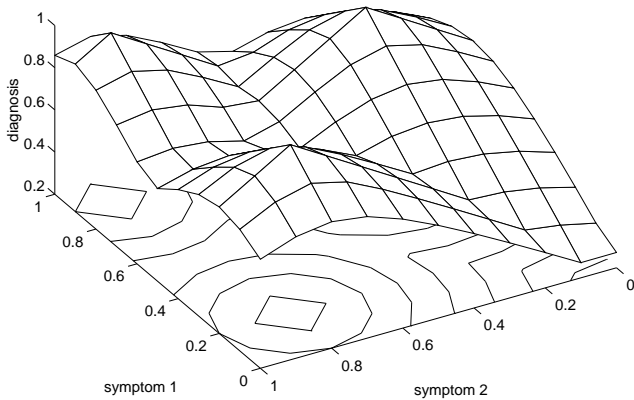

Fig. 5: Modeling of three faults with two symptoms using  $\gamma_C$

## Graphical Representation of Fuzzy Belief Nets

In the previous sections we discussed the tools necessary for inverting a fuzzy relation (arc reversal in FBN). This section introduces notation for operations on the topological level of the FBN. Specifically, we explain the types of nodes involved and how to deal with different connections which are expressed through AND/OR linguistically in the antecedents and consequents of rules. Each introduced operator is followed by a practical example. The section concludes with a more complex illustrative example.

## Notation

The graphical representation of fuzzy belief nets consists of nodes and arcs. The nodes are either state nodes which correspond to the uncertain quantities which are not under direct control or control nodes where the variable is under direct control. As in probabilistic belief nets the state nodes are shaped circular (Agogino et al., 1988). Arcs between nodes represent the (fuzzy) causal relations from one state to the other as displayed in Fig. 6.



Fig. 6: Fuzzy causal relation represented by arc between two state nodes

Three types of state nodes are used for applications in diagnostic reasoning: 1.) sensor nodes which can be directly observed; 2.) failure nodes which represent the physical components in the system which are subject to diagnostic search. Failure nodes are the cause for symptoms observed (Goebel, 1996); 3.) finally, intermediate nodes which are useful for modeling the belief net but are not the goal or conditioning nodes. Rather, they often represent intangibles in the problem which are not directly measured. Fig. 7 shows the three types of nodes.

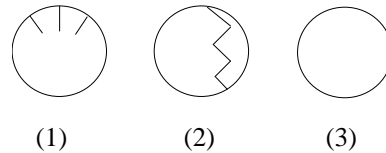

Fig. 7: State nodes: (1) sensor, (2) failure, (3) intermediate

The inference engine for diagnosis starts from the observation of measurements obtained from sensors and chains through the belief net to obtain degrees of truth for failures and to find the causes for failures. There are several basic operations which are used with fuzzy belief nets. These operations originate in the interpretation of the arc which is understood as a fuzzy rule of the form IF fault A THEN symptom B. Fig. 8 shows the model for this basic rule.



Fig. 8: Fuzzy rule: IF A THEN B

As an example the rule will be used that the temperature of a system rises a lot when the valve gets stuck. This rise is modeled to cause the associated symptom to a degree 0.7. The matrix representation of this rule is expressed in Table 2.

Table 2: Matrix representation of rule: IF valve gets stuck THEN temperature rise large

$s_B$	$f_A$
0	0
0.7	1

Assuming an observation of “temperature rise large” of 0.6 and using the closeness measure  $\gamma_C$ , the result is computed to be  $\gamma_C=0.9$ .

**AND Antecedent.** More complex rules involve the use of “AND” and “OR” operators which implies there are two or more antecedents or consequents. Here, only combinations of two antecedents or consequents with “AND” and “OR” operators are shown. The extension to cases involving more than two operands is straight forward. The rule “IF A AND B THEN C” is displayed using the graphical representation in Fig. 9. Note the AND-operator displayed next to node C.

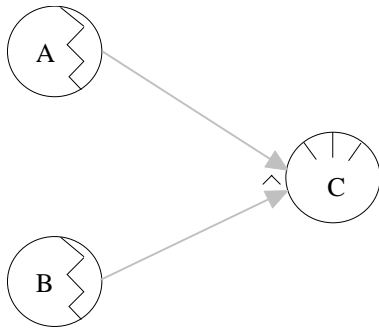

Fig. 9: Fuzzy rule: IF A AND B THEN C

For calculation purposes, this rule is reduced to the following representation (Fig. 10):



Fig. 10: Alternative representation for rule: IF A AND B THEN C

The two arcs are replaced by one single arc which carries the weight of the minimum weight of the two arcs. The diagnosis has the same value for both antecedents A and B. As a consequence, the rule “IF valve stuck AND bypass clogged THEN temperature rise large” uses a similar matrix representation as used in Table 1.

**OR Antecedent.** The rule “IF A OR B THEN C” is represented graphically as displayed in Fig. 11. Note the OR-operator displayed next to node C.

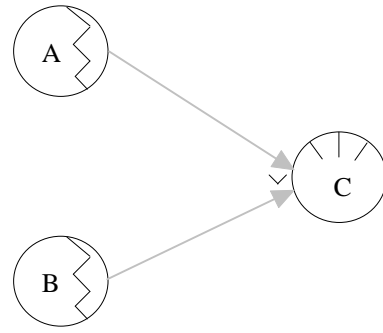

Fig. 11: Fuzzy rule: IF A OR B THEN C

This rule is equivalent to the three representations as displayed in Fig. 12.

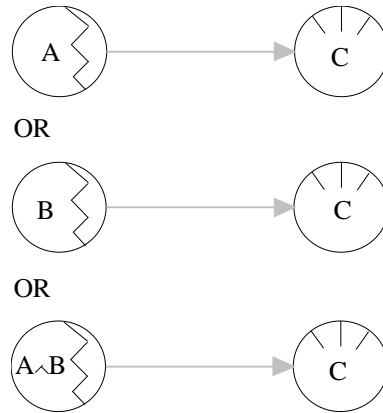

Fig. 12: Alternative representation for rule: IF A OR B THEN C

The matrix representation for rule “IF valve stuck OR pipe leaks THEN pressure drops is medium” is shown in Table 3.

Table 3: Matrix representation of rule: IF valve gets stuck OR pipe leaks THEN pressure drop medium

$s_C$	$f_A$	$f_B$
0	0	0
0.8	0	1
0.7	1	0
0.8	1	1

The closeness measure will be calculated for each case and the maximum closeness measure is used as the most likely candidate. Notice that in this model the failure “A and B” has higher degree of complexity and will not be considered with the presumption of minimum cardinality for the solution because each solution based on one sensor observation will render equal results for A and “A AND B”. For an observation of 0.6, the closeness measure is  $\gamma_C=0.9$ .

**AND Consequent.** The rule IF A THEN B AND C is displayed with the graphical representation in Fig. 13 where the  $\wedge$ -operator is shown next to node A.

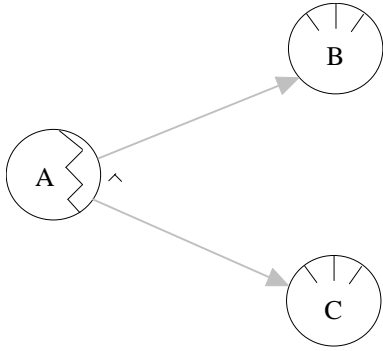

Fig. 13: Fuzzy rule: IF A THEN B AND C

The rule “IF valve stuck THEN temperature rise large AND pressure drop medium” can be represented in matrix notation as shown in Table 4.

Table 4: Matrix representation of rule: IF valve gets stuck THEN temperature rises AND pressure drops

$s_B$	$s_C$	$f_A$
0	0	0
0.6	0.3	1

With an observation of  $\begin{bmatrix} 0.5 \\ 0.4 \end{bmatrix}$ , the closeness measure for this example is  $g_c=0.8586$ .

**OR Consequent.** For the rule “IF A THEN B OR C” the graphical representation is shown in Fig. 14 where the  $\vee$ -operator is displayed next to node A.

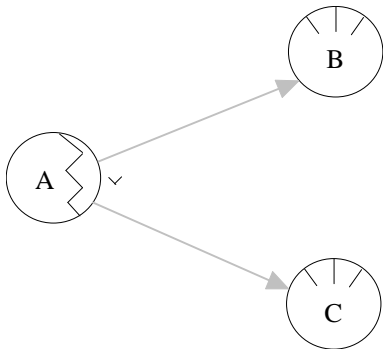

Fig. 14: Fuzzy rule: IF A THEN B OR C

This rule can be decomposed into three cases as displayed in Fig. 15.

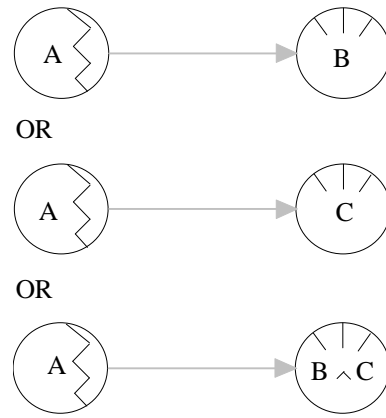

Fig. 15: Alternative representation for rule: IF A THEN B OR C

The matrix representation for rule “IF valve stuck THEN temperature rise large OR pressure drop medium” is shown in Table 8.

Table 5: Matrix representation of rule: IF valve gets stuck THEN temperature rise large OR pressure drop medium

$s_B$	$s_C$	$f_A$
0	0	0
0.6	0	1
0	0.3	1
0.6	0.3	1

## Illustrative Example

The same relations can be used to propagate the evidence for arcs connecting any combination of sensor nodes, failure nodes, source nodes, and intermediate nodes. To explain the concept further, an illustrative example will be used which has more complex connections. Consider the network as displayed in Fig. 16 where

A is the root cause (failure) that there are particles in the flow

B is the root cause (failure) that the fluid is corrosive

C is the state that the valve is stuck

D is the state that the pipe leaks

E is the sensor observation that the temperature rises a lot

F is the sensor observation that the pressure drop is medium

G is the sensor observation that the temperature is down slightly

The numbers next to the arc are the membership values for the rule represented by the arc. The rules are:

- IF there are particles in the flow THEN the valve is stuck
- IF the fluid is corrosive THEN the valve gets stuck OR the pipe leaks
- IF the valve is stuck THEN the temperature rises a lot AND the pressure goes down medium
- IF the pipe leaks THEN the pressure goes down medium AND the temperature goes down slightly

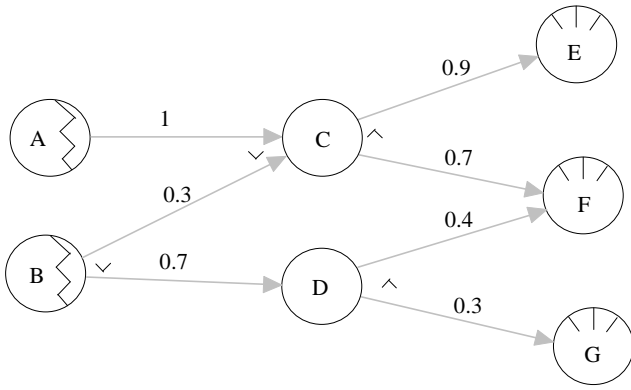

Fig. 16: Fuzzy belief net: illustrative example

Let the observation for the sensors be  $\begin{bmatrix} s_E \\ s_F \\ s_G \end{bmatrix} = \begin{bmatrix} 0.8 \\ 0.4 \\ 0.1 \end{bmatrix}$ .

Using the rules established earlier, the first step in backpropagating the evidence results in the calculation of the closeness for intermediate nodes C and D. Both nodes have an AND connection to the symptoms observed. The closeness measure for node C is calculated as  $\gamma_c=0.6838$ , the closeness measure for node D is  $\gamma_c=0.8$ , and the closeness measure for event C AND D is  $\gamma_c=0.6258$ . The operations are illustrated in

Fig. 17.

$s_E$	$s_F$	$f$	$\gamma_c$
0	0	0	0.1056
0.9	0.7	1	0.6838

$s_E$	$s_F$	$s_G$	$f_{C \wedge D}$	$\gamma_c$
0	0	0	0	0.1
0.9	0.7	0.3	1	0.6258

$s_E$	$s_F$	$f$	$\gamma_c$
0	0	0	0.5877
0.4	0.3	1	0.8

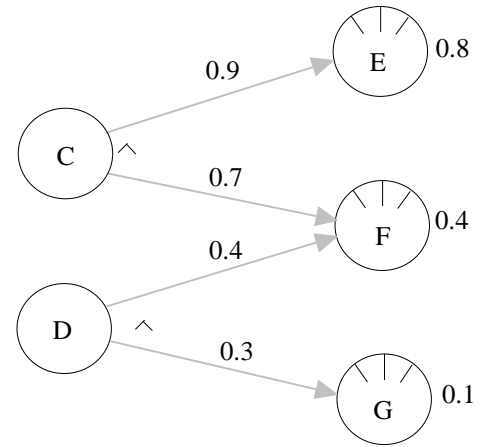

Fig. 17: Operations to solve fuzzy influence diagram; example case

To find the failure root, the highest closeness measure is taken while the others are disregarded. In this case, node D ( $\gamma_c=0.8$ ) is chosen. Since only one failure node is modeled for the event under consideration, the task is trivial and reduces to failure B as shown in Fig. 18.

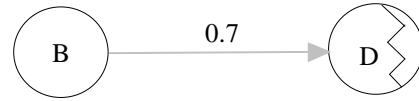

Fig. 18: Source B is found as cause for the failure; example case

Had the observation been such that node C was diagnosed, e.g.  $\begin{bmatrix} s_E \\ s_F \\ s_G \end{bmatrix} = \begin{bmatrix} 0.8 \\ 0.8 \\ 0.1 \end{bmatrix}$ , the closeness measure for nodes C, D, and  $C \wedge D$  would have been  $\gamma_c(f_C) = 0.8586$ ,  $\gamma_c(f_D) = 0.5528$ , and  $\gamma_c(f_{C \wedge D}) = 0.7551$ , respectively. In that case, propagation of evidence from the intermediate nodes to the failure nodes is performed on both possible branches (as shown in Fig. 22) to result in  $\gamma_c(S_A) = 0.8586$ ,  $\gamma_c(S_B) = 0.4414$ , and  $\gamma_c(S_{A \wedge B}) = 0.4238$ . The interpretation of these results is that failure A is more likely than failure B and the combined failure  $A \wedge B$ . A remedial plan has to move according to these results.

$s_E$	$s_F$	$s_G$	$f_C$	$f_D$	$\gamma_c$
0	0	0	0	0	0.1414
--	0.4	0.3	0	1	0.8586
0.9	0.7	--	1	0	0.4414
0.9	0.7	0.3	1	1	0.4238

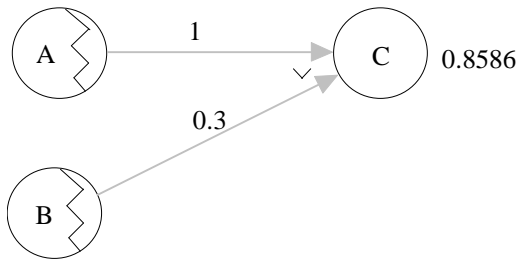

Fig. 19: Failure C is found as the failure; modified example case

## Conclusions

The proposed approach suggests how closeness operators  $\gamma_c$  and  $\gamma_s$  can be used to model fuzzy belief nets. In particular, arc reversal is demonstrated. The calculation of the closeness measure uses distance metrics from the observed symptom set to the symptom set for a failure combination and – in the case of soft failures – distance measures to the failure line. The closeness measure for soft failures allows to determine to which degree a failure occurs. It calculates the distance to the failure line as a measure for the degree of the symptom and the distance from origin to intersection with shortest distance, normed by the overall length of the failure line, as a measure for the strength of the failure. Advantages of this approach overcomes shortcomings of previous fuzzy approaches where solutions are not always given, have an unacceptable large upper and lower bound, or are accomplished by manually reverting rules. Insufficiencies of threshold driven diagnosis are eliminated because the approach avoids assumptions of failure independence and of relative frequency of disorder occurrence. Links in the fuzzy belief net are represented as causal strengths for failure-symptom relations similar to the Bayesian approach.

Additional expert knowledge about the behavior of multiple fault-symptom relations can be incorporated into the system model which may result in placement of combined faults at locations other than the maxima of their symptoms when the failures are (partially) canceling their symptoms or when the straight line model for the failure behavior is known to be incorrect.

While this is a first step at representing FBNs and reverting arcs, future work will explore automation issues. Likewise the issue of combinatorial complexity is subject to more research. Possible extensions of this work also include the development of fuzzy influence diagrams using a fuzzy utility measure.

## References

1. Miller, A.C., Merkhofer, M.M., Howard, R.A., and Matheson, J.E., 1976. Development of Automated Aids for Decision Analysis, prepared for the Defense Advanced

- Research Projects Agency (DARPA), Menlo Park, California, SRI International.
2. Olmstead, S.M., 1984. On Representing and Solving Decision Problems, PhD thesis, Department of Engineering-Economic Systems, Stanford University.
3. Shachter, R.D., 1984. Automating Probabilistic Inference, Presented at the Nineteenth Actuarial Research Conference - 1984, Credibility Theory and Bayesian Approximation Methods, University of California, Berkeley.
4. Agogino, A., and A. Rege. 1987. IDES: Influence Diagram Based Expert System“, *Mathematical Modeling*, **8**.
5. Jain, P., and Agogino, A. 1990. Stochastic Sensitivity Analysis using Fuzzy Influence Diagrams“, *Proceedings of the Fourth AAAI Workshop on Uncertainty in Artificial Intelligence*, Revised version published in *Uncertainty in Artificial Intelligence 4*, eds., R.D. Shachter, T.S. Levitt, L.N. Kanal, J.F. Lemmer; Elsevier Science Publishers V.V., North-Holland Press.
6. Sanchez, E., 1976. Resolution of Composite Fuzzy Equations“, *Inf. Control*, **30**.
7. Mizumoto, M. & Zimmermann, H.-J., 1982. Comparison of Fuzzy Reasoning Methods“, *Fuzzy Sets and Systems*, **8**, No. 3.
8. Gmytrasiewicz, P., Hassberger, J.A., and Lee, J.C., 1990. Fault Tree Based Diagnostics Using Fuzzy Logic“, *IEEE Transactions on Pattern Analysis and Machine Intelligence*, **12**, No. 11.
9. Ulieru, M., 1994. Diagnosis by Approximate Reasoning on Fuzzy Fault Trees“, Proceedings of the third IEEE Conference on Fuzzy Systems“, *IEEE World Congress in Computational Intelligence*, Orlando, FL.
10. Engemann, K.J., Miller, H.E., Yager, R.R., 1996. Decision Making with Belief Structures: An Application in Risk Management“, *International Journal of Uncertainty, Fuzziness and Knowledge-Based Systems*, **4**, No.1.
11. Hisdal, E., 1978. Conditional Possibilities, Independence and Noninteraction“, *Fuzzy Sets and Systems*, **1**, No.1.
12. Dubois, D. & Prade, H., 1992. Possibilistic Abduction“, *IPMU '92 - Advanced Methods in Artificial Intelligence*, Proceedings of the 4th International Conference in Information Processing and Management of Uncertainty in Knowledge-Based Systems, Palma de Mallorca, Spain.
13. Kosko B., 1986. Fuzzy Entropy and Conditioning“, *Information Sciences*, **40**, No. 2.
14. Dalton, R. 1993. Towards a Theory of Fuzzy Causality for Diagnosis“, *Information Sciences*, Vol. 80.
15. Peng, Y. & Reggia, J.A., 1990. *Abductive Inference Models for Diagnostic Problem-Solving*, (Springer-Verlag, New York).
17. Goebel, K., 1996. Management of Uncertainty in Sensor Validation, Sensor Fusion, and Diagnosis of Mechanical Systems Using Means from Soft Computing“, Ph.D. Thesis, University of California at Berkeley.
18. Agogino, A., Srinivas, S. and Schneider, K., 1988. Multiple Sensor Expert System for Diagnostic Reasoning, Monitoring, and Control of Mechanical Systems,“ *Mechanical Systems and Signal Processing*, **2** (2), pp. 165-185.