



# METHODOLOGY APPROACH TO MODULAR DESIGN

## Diversity Modeling in Product Family

**Blaise MTOPI - Ph.D.**  
**mtopi@yahoo.com**

**Laboratoire d'Automatique de Besançon – LAB**  
**France**  
**COSMI TEAM**  
**Maryvonne DULMET and Eric BONJOUR**

**UC Berkeley, October 05, 2007**



Outline

Problematic

Product Family

Modeling using graph grammar

Modeling using matrix transformations

Conclusion and prospect

● **Problematic**

● **Product Family**

● **Modeling using graph grammar**

● **Modeling using matrix transformations**

● **Conclusion and prospect**



Outline

Problematic

Product Family

Modeling using graph grammar

Modeling using matrix transformations

Conclusion and prospect

**News ways to design and to produce**

**Product of better quality, to a low cost and with a shorter market delay**

**Better control of the process of design of new product**

**To take or preserve a competing advantage**

**Management of the design project:**

**Sequential process**

**« simultaneous engineering »**





- Outline
- Problematic
- Product Family
- Modeling using graph grammar
- Modeling using matrix transformations
- Conclusion and prospect

**Diversification of the needs**

A single (unique) product able to satisfy the needs for all the customer

A product to order respondent to the needs of a specific customer

**Over cost of the useless functions**

**Production cost**

**The designers choose intermediate strategies**

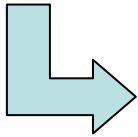

To manage diversity  
To reason by product family



# Of what the diversity management consists ?

[Agard, 2004]

- Outline
- Problematic
- Product Family
- Modeling using graph grammar
- Modeling using matrix transformations
- Conclusion and prospect

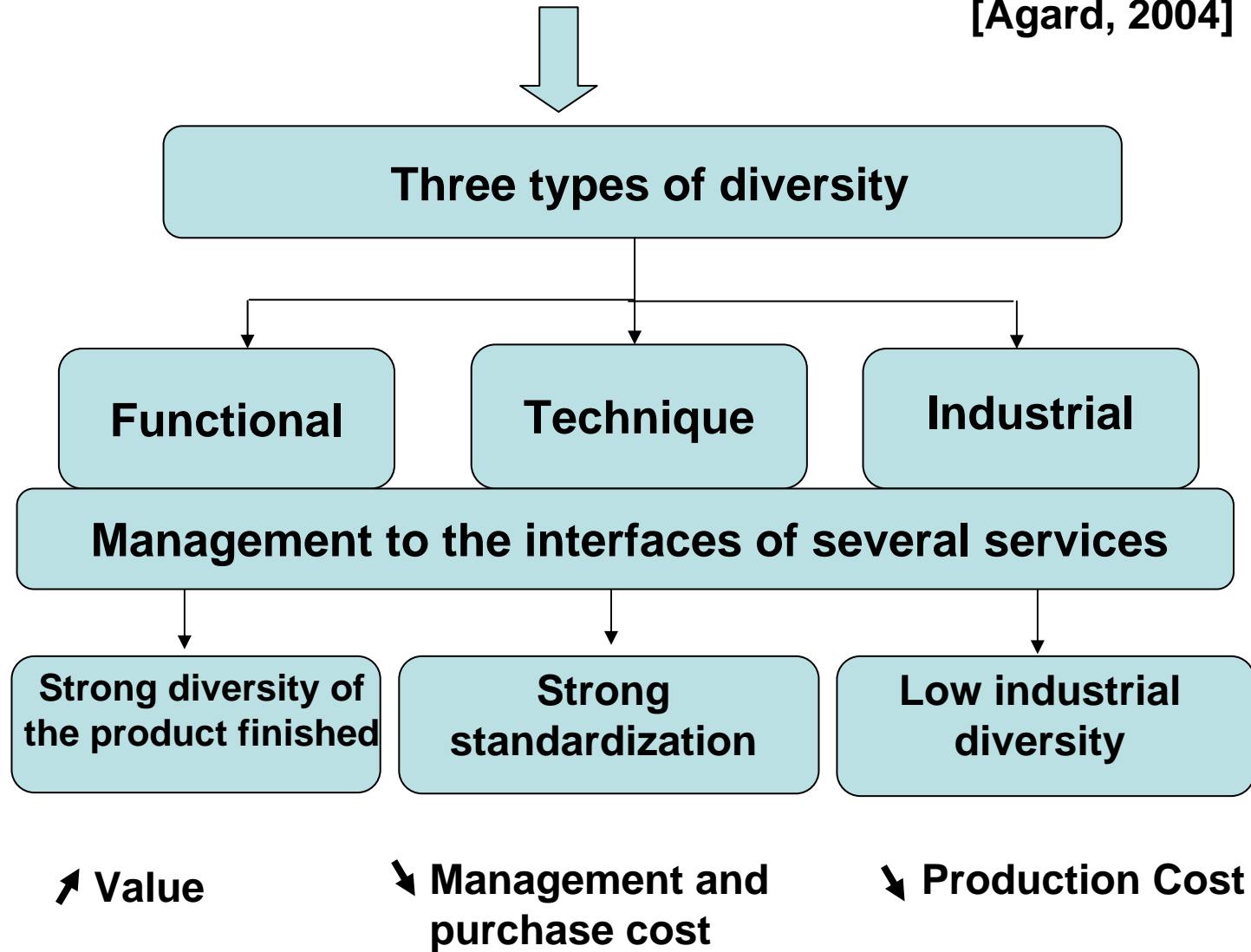



# Of what the diversity management consists ?

- Outline
- Problematic
- Product Family
- Modeling using graph grammar
- Modeling using matrix transformations
- Conclusion and prospect

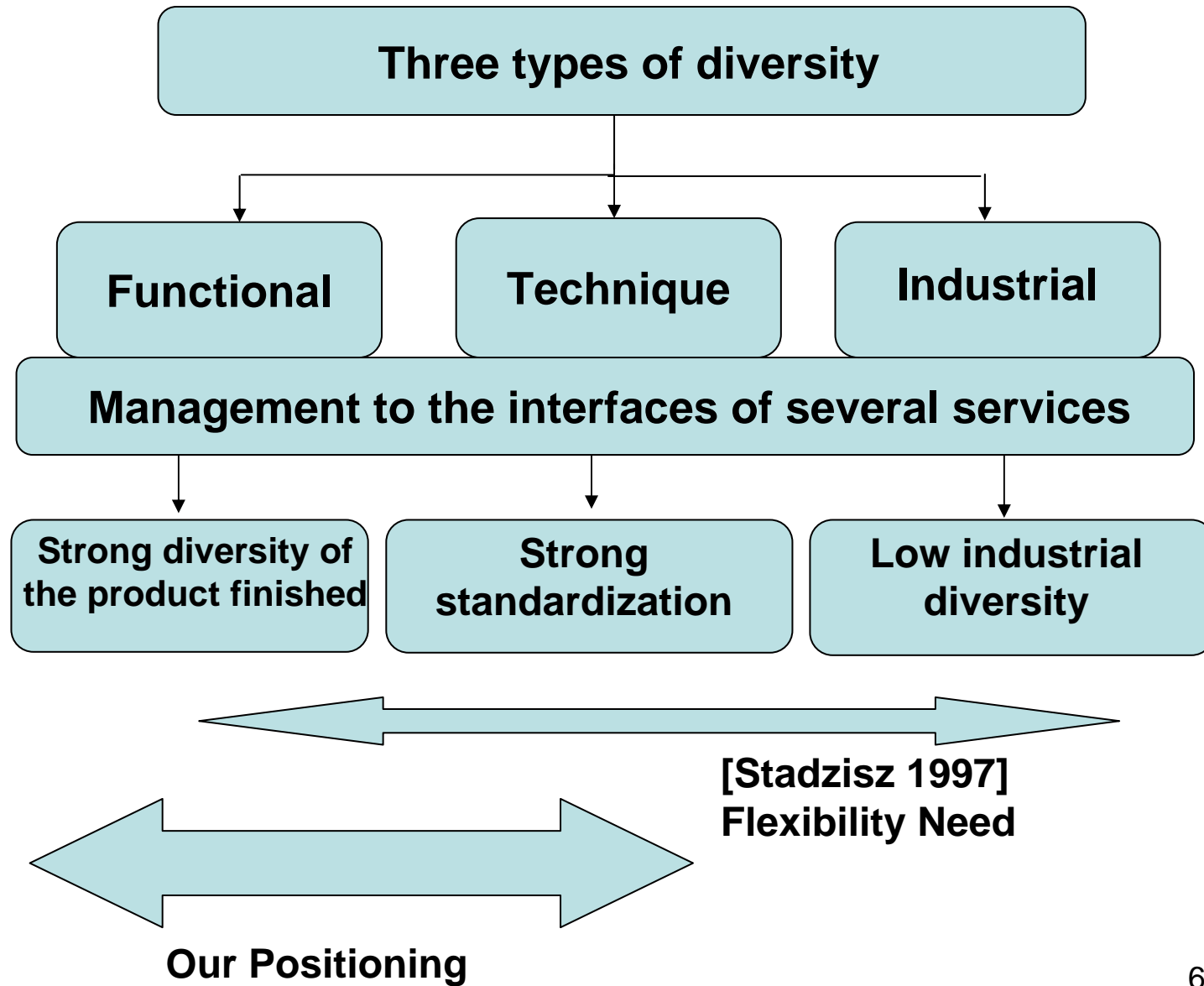



Outline

Problematic

Product Family

Modeling using graph grammar

Modeling using matrix transformations

Conclusion and prospect

## Strategies of diversity management

Several approaches of product design permit to define a set of products from standardized elements :

**The Postponement**

**The standardization and the group technology**

**The modular design**





# Of what consist the modular design ?

Outline

Problematic

Product Family

Modeling using graph grammar

Modeling using matrix transformations

Conclusion and prospect

To share the components between different functions and / or different products

**Modular components**

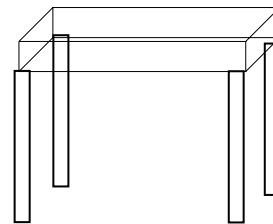
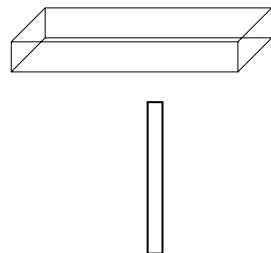

**A stool**

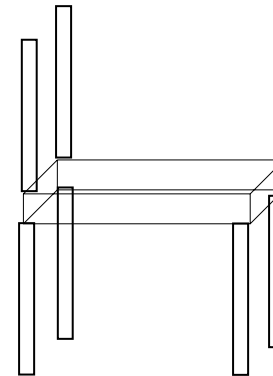

**A chair**

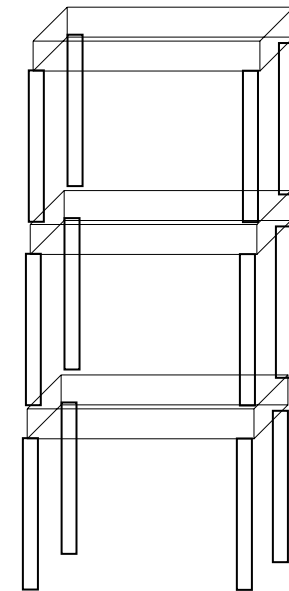

**(racks)**

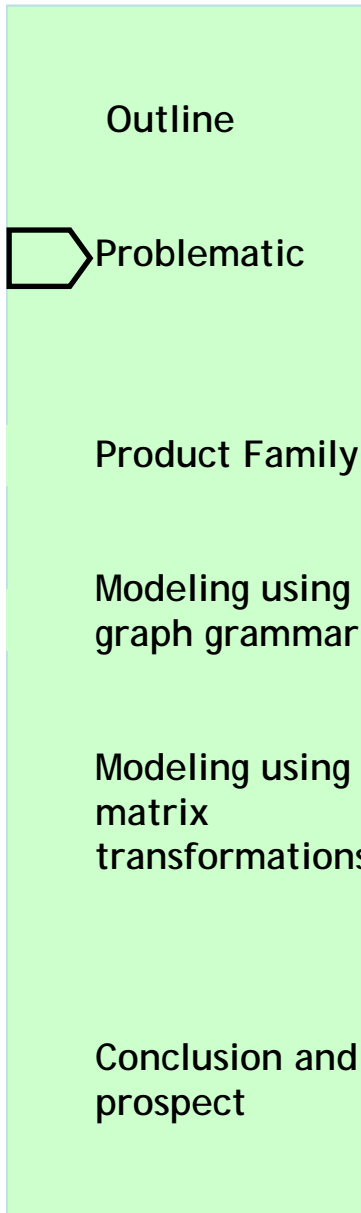

## **Industrial Problematic**

**To manage diversity in Products Families**

## **Academic Problematic**

**To modeling the Product Family Architecture**

**Modeling by :**  
**- graph grammar**  
**- matrix transformation**



# Terminology on « Products Families »

It doesn't exist a universal terminology

The different definitions lean on the following properties:

**Common Functions**

**Common Components**

**Common Characteristics**

**Common Process of production**

**Common Technologies**

Outline

Problematic

Product Family

Modeling using graph grammar

Modeling using matrix transformations

Conclusion and prospect



Outline

Problematic

Product Family

Modeling using graph grammar

Modeling using matrix transformations

Conclusion and prospect

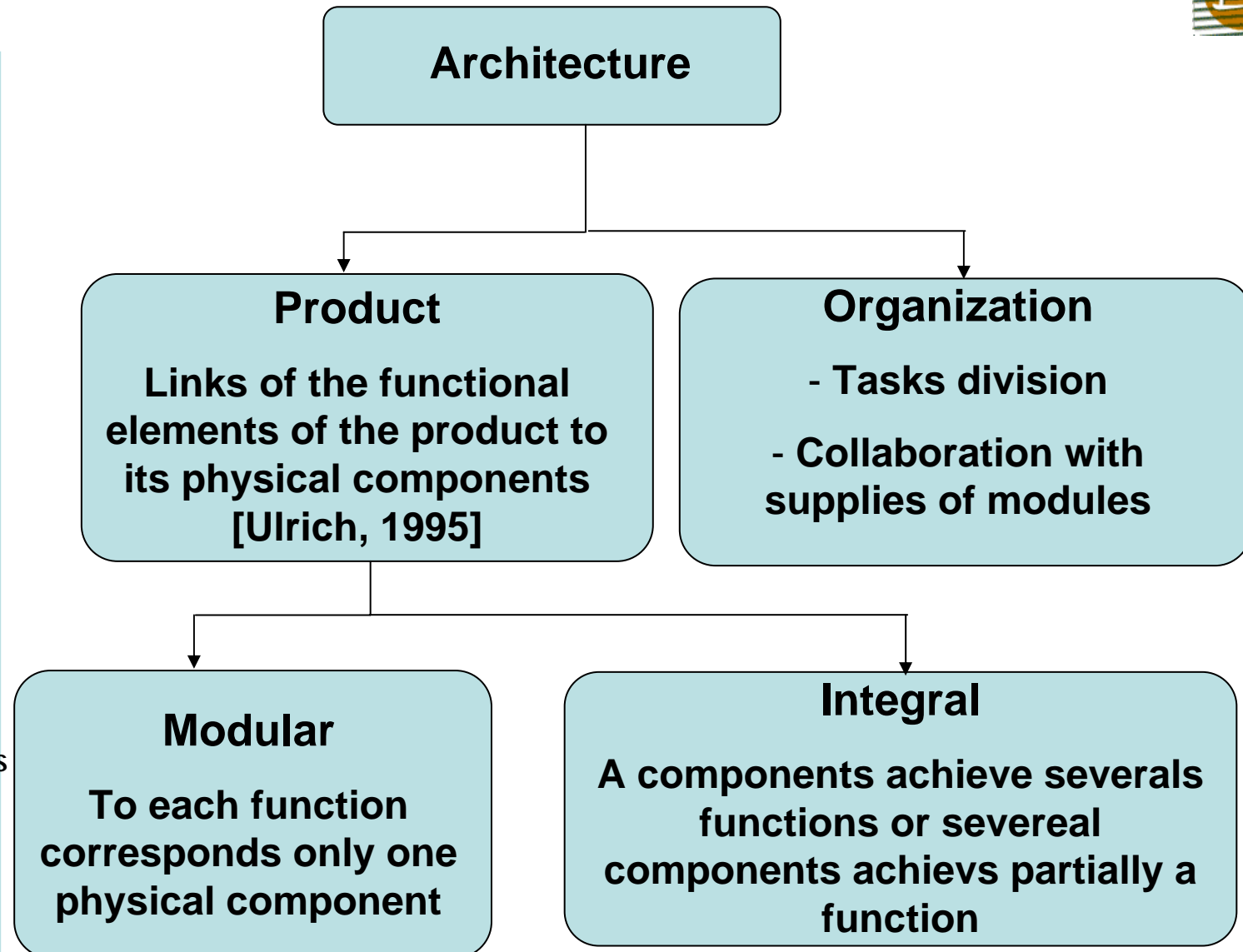



# Compared analysis of the modular and integral architecture



- Outline
- Problematic
- Product Family
- Modeling using graph grammar
- Modeling using matrix transformations
- Conclusion and prospect

|                       | Scale Economy | Improvement on the product   | Diagnosis and maintenance           | Protection of the solutions | Collaboration and sharing of the knowledge |
|-----------------------|---------------|------------------------------|-------------------------------------|-----------------------------|--|
| Modular Architecture  | Strong        | Impacts on a module          | Comfortable<br>Change of the module | Weak                        | Weak                                       |
| Integral Architecture | Low           | Impacts on the whole product | Difficult                           | Strong                      | Strong                                     |





# Generic Product Structure

Outline

Problematic

Product Family

Modeling using graph grammar

Modeling using matrix transformations

Conclusion and prospect

[Du et al., 2001, 2002]

**Commons Module** (All variants of the product family)

**Distinctives Module** (Compound, primitive)

**Variants different ones from the others**

**The generic product structure is the hierarchical structuring of these two types of modules.**

**The base product represent the common modules from which the variant product can be obtained.**



# Application to a industrial case study

Outline

Problematic

Product Family

Modeling using  
graph grammar

Modeling using  
matrix  
transformations

Conclusion and  
prospect

Case of the integrated kitchen design

- Products to strong diversity and modular character

To illustrate our models, we are interested in a low ranging  
Piece of furniture.



Outline

Problematic

Product Family

Modeling using graph grammar

Modeling using matrix transformations

Conclusion and prospect

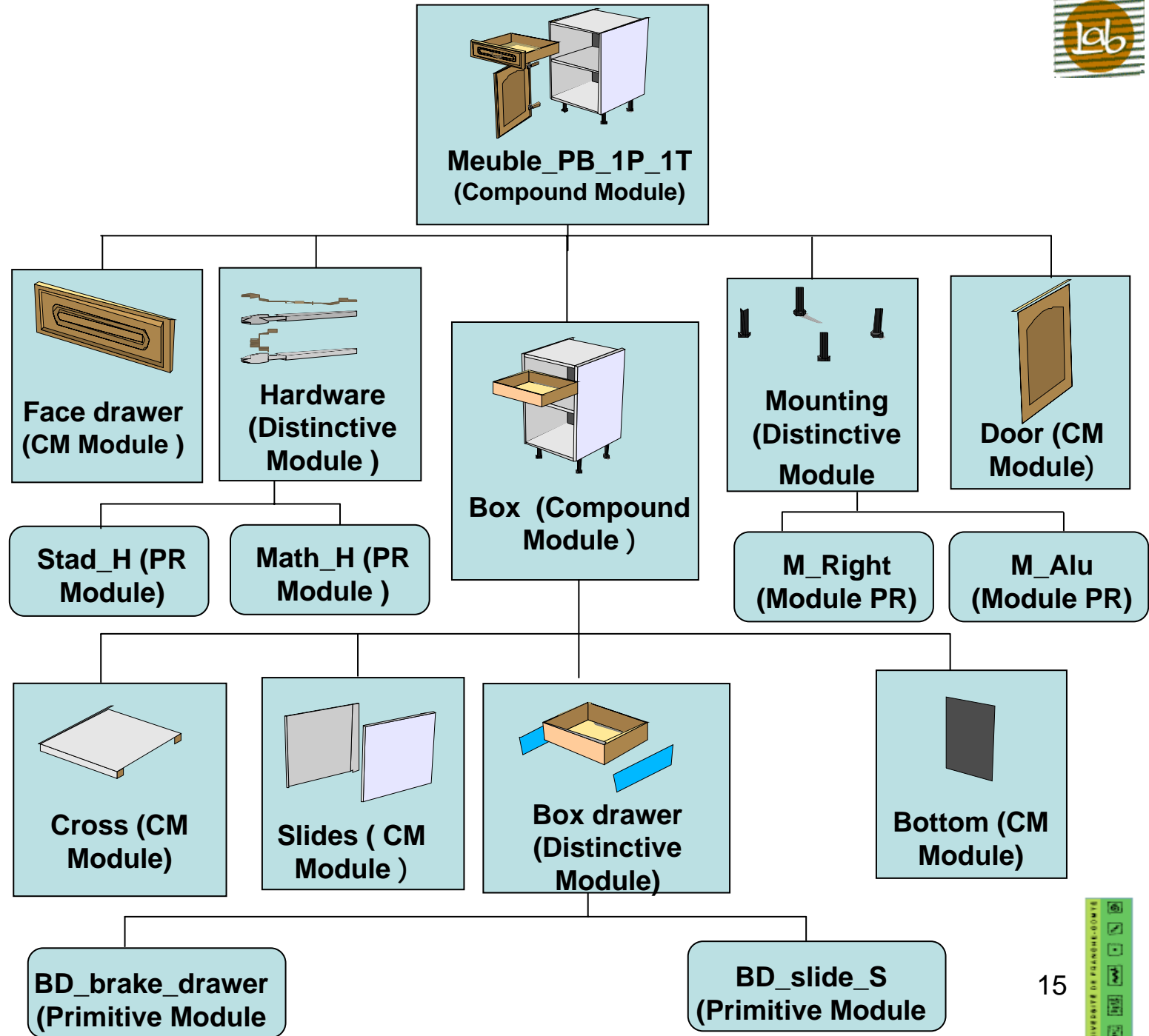



# Correspondance between formal language and product family

[Djemel, 1994]

- Ouline
- Problematic
- Product Family
- Modeling using graph grammar
- Modeling using matrix transformations
- Conclusion and prospect

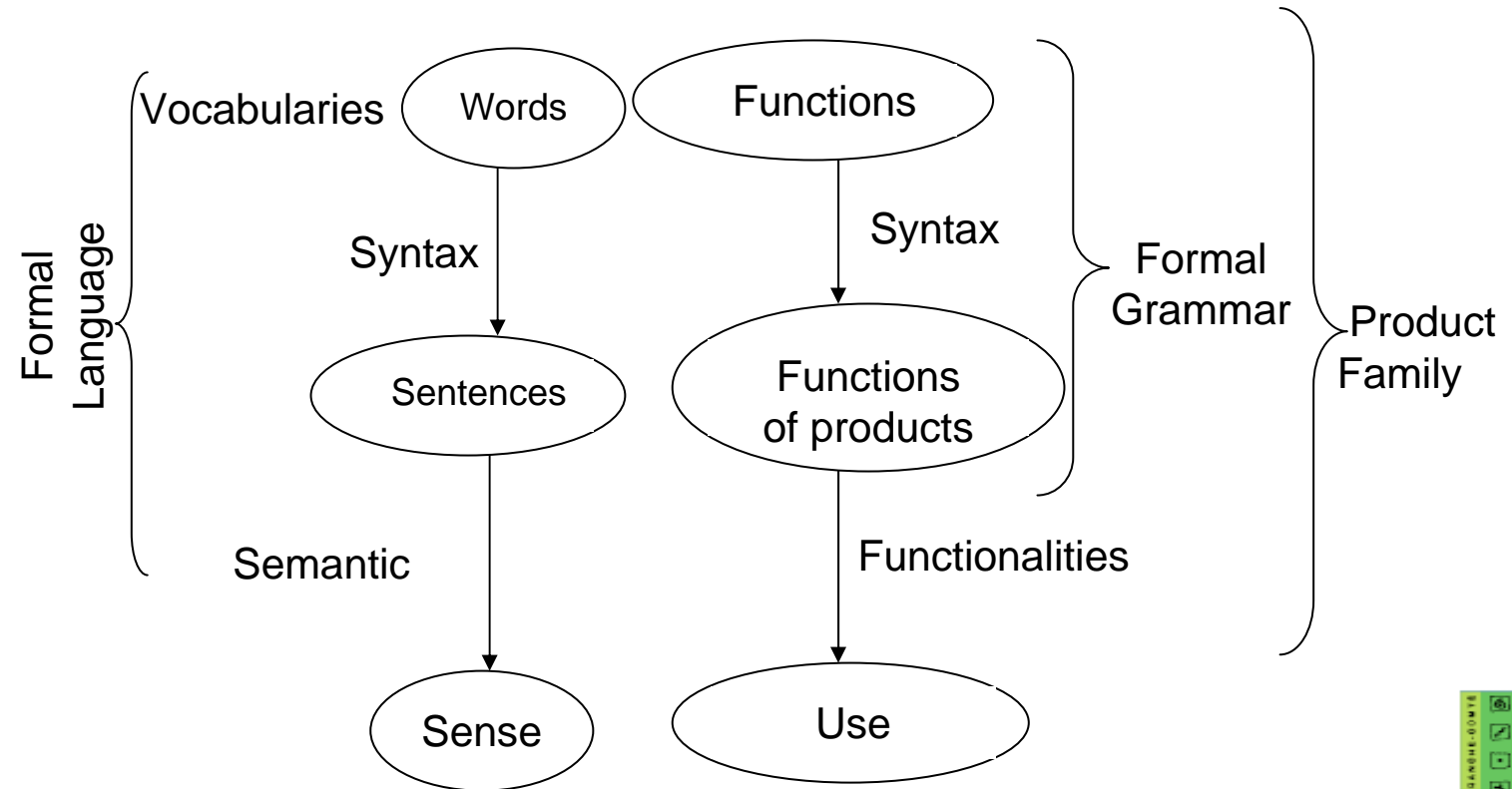



## Formal Grammar

$$G = (V_N, V_T, S, P)$$

$V$  Vocabulary

$V_T \subset V$  Terminal Vocabulary

$V_N = V - V_T$  Non Terminal Vocabulary

$S$  Distinct element of  $V_N$  called initial symbol

$P$  Finite set defining production rules

Outline

Problematic

Product Family

Modeling using  
graph grammar

Modeling using  
matrix  
transformations

Conclusion and  
prospect



## Web Grammar [Pfalz and Rosenfeld, 1969]

Outline

Problematic

Product Family

Modeling using graph grammar

Modeling using matrix transformations

Conclusion and prospect

Set of labeled graph « Web » whose production consists to replace a « sub web » by another « sub web »

**Idem general principles that the formal grammars**

$$G = (V_N, V_T, S, P)$$

**In this 4-tuple, the production rule is a 3-tuple**

$$(\alpha, \beta, f)$$

$$\alpha \rightarrow \beta \quad f$$



## Interest of using web grammars :

- generative character
- possibility to describe the multi graphs modeling the product family [Stadzisz, 1997]

## Limits for the product family modeling :

- difficulty to fear the constraints of components and modules combinations (essentials in product family)
- need of a extension knowledge when a important number of variants exists :

- combinative explosion

- model update is difficult for a product family



## Graph Grammars

Outline

Problematic

Product Family

Modeling using graph grammar

Modeling using matrix transformations

Conclusion and prospect



## PAGG (Programmed Attributed Graph Grammars)

[Bunke, 1982]

**The graph grammar for a compound module,  $M$ , is a 6-tuple, denote as**

$$G(M) \cong (V, W, A, G^i, P, C)$$

Outline

Problematic

Product Family

Modeling using graph grammar

Modeling using matrix transformations

Conclusion and prospect

**V Node labels**

**W Edges labels**

**A Node attributes**

**$G^i$  Starting graph representing the base product**

**P Production rules**

**C Control diagram over P**



# Application to a industrial case study



Outline

Problematic

Product Family

Modeling using graph grammar

Modeling using matrix transformations

Conclusion and prospect

Edge labeled

| Denomination of the type of link           | Nomenclature |
|--|--------------|
| Direct rotation = pivot link               | piv          |
| Solidarisation by fixed pivot = fix link   | fix          |
| Solidarisation by staples = fix link       | fix          |
| Solidarisation by fixed screw = fix link   | fix          |
| Groove = embedding link                    | enc          |
| Solidarisation by fitment = embedding link | enc          |
| Slide = Slide link                         | gli          |



# Application to a industrial case study

Instantiation of the 6-tuple of box graph grammar

Outline

Problematic

$$G(M_{BOX}) \cong (V_{BOX}, W_{BOX}, A_{BOX}, P_{BOX}, G_{BOX}^i, C_{BOX})$$

Product Family

$$V_{BOX} = \{M_{BD\_BD}, M_{BD\_SS}, M_{F\_DRA}, M_{SLID}, M_{H\_CRS}, M_{L\_CRS}, M_{DOOR}, M_{BOTT}, M_{S\_SYS}\}$$

Modeling using graph grammar

$$W_{BOX} = (gli, fix, enc, piv)$$

Modeling using matrix transformations

$$A_{BOX}$$

$$P_{BOX} = \{P_{BD\_BD}, P_{BD\_SS}\}$$

$$G_{BOX}^i = G(M_{BOX}^0)$$

Conclusion and prospect

$$C_{BOX}$$





# Encapsulated Graph of the primitive module Box Drawer with Brake

- Outline
- Problematic
- Product Family
- Modeling using graph grammar
- Modeling using matrix transformations
- Conclusion and prospect

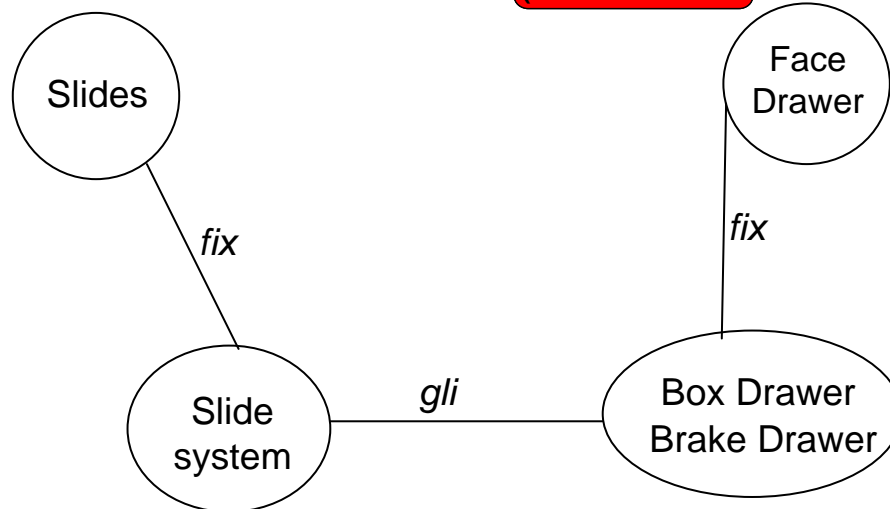
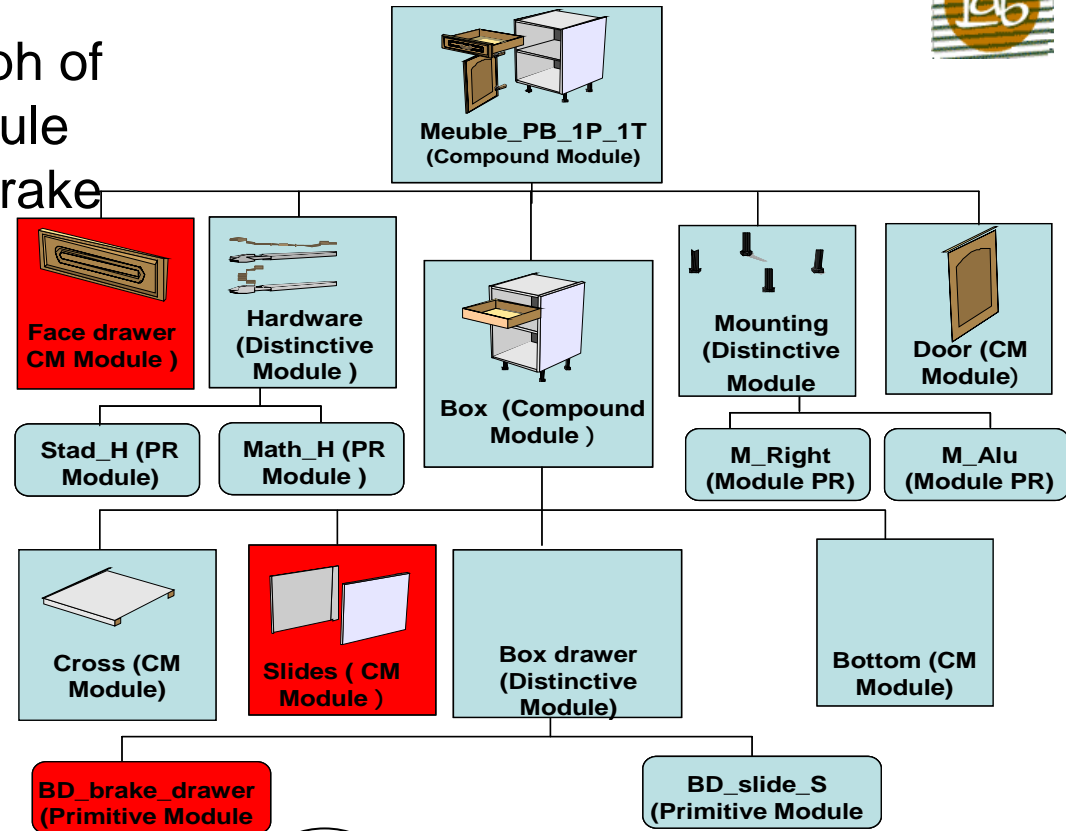

$$g_d = G(M_{BD\_BD})$$



# Encapsulated Graph of the primitive module Box Drawer with Standard Drawer

- Outline
- Problematic
- Product Family
- Modeling using graph grammar
- Modeling using matrix transformations
- Conclusion and prospect

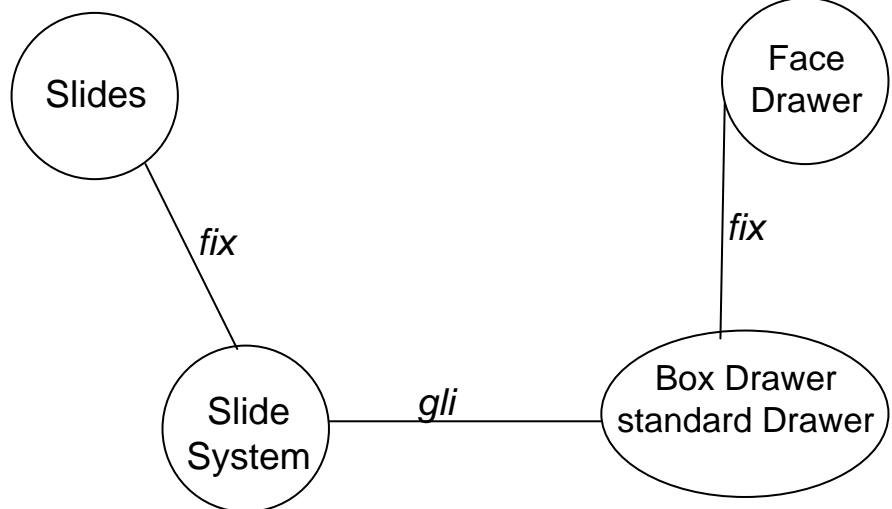
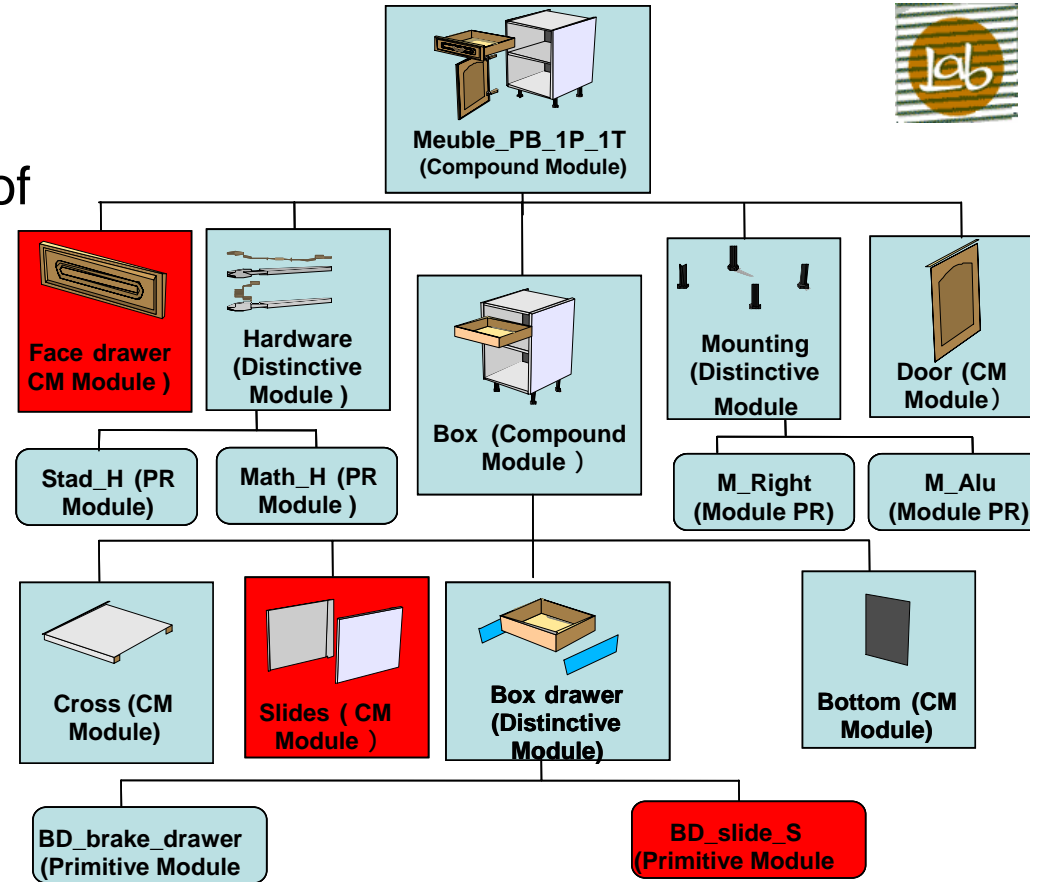

$$g_d = G(M_{BD\_SS})$$





# Definition of encapsulated graphs for the family of box products



Outline

Problematic

Product Family

Modeling using graph grammar

Modeling using matrix transformations

Conclusion and prospect

|          | $G(M_{BOX}^0)$   | $G(M_{BD\_BD})$                               | $G(M_{BD\_SS})$                               |
|----------|--|---|---|
| $S_c$    | {(DOOR, BOTT, SLID, L_CRO, H_CRO)}                                     | {BD_BD, SLID, F_DRA, S_SYS}                   | {BD_SS, SLID, F_DRA, S_SYS}                   |
| $S$      | {BOTT, SLID, L_CRO, H_CRO}   | {BD_BD}                                       | {{BD_SS}}                                     |
| $A_c$    | {(DOOR,SLID), (BOTT,SLID), (BOTT,H_CRO), (BOTT, L_CRO), (H_CRO, SLID)} | {(SLID, S_SYS), (S_SYS,BD_BD), (BD_BD,F_DRA)} | {(SLID, S_SYS), (S_SYS,BD_SS), (BD_SS,F_DRA)} |
| $A$      | $\emptyset$  | $\emptyset$                                   | $\emptyset$                                   |
| $S_{cp}$ | $\emptyset$  | $\emptyset$                                   | $\emptyset$                                   |
| $S_{pr}$ | $\emptyset$  | {BD_BD}                                       | {BD_SS}                                       |
| $S_{cm}$ | $\emptyset$  | $\emptyset$                                   | $\emptyset$                                   |
| $S_{ct}$ | {DOOR}   | {SLID, F_DRA, S_SYS}                          | {SLID, F_DRA, S_SYS}                          |
| $A_{ct}$ | {(DOOR,SLID), (BOTT,SLID), (BOTT,H_CRO), (BOTT, L_CRO), (H_CRO, SLID)} | {(SLID, S_SYS), (S_SYS,BD_BD), (BD_BD,F_DRA)} | {(SLID, S_SYS), (S_SYS,BD_SS), (BD_SS,F_DRA)} |



Outline

Problematic

Product Family

Modeling using graph grammar

Modeling using matrix transformations

Conclusion and prospect

Variety generation is modeled by specifying [Ulrich, 1995]



Production

A production consist of two elements

$$p \cong (O, \pi)$$

**O the operation and its applications conditions**

$O \in \{\text{Attaching, Removing, Swapping, Scaling}\}$ [Du et al., 2002]

$\pi \in \{\text{TRUE, FALSE}\}$  Applicability predicate



# Application to a industrial case study

## Definition of productions

Outline

Problematic

Product Family

Modeling using graph grammar

Modeling using matrix transformations

Conclusion and prospect

The customer can require a Box Drawer module provided with a opening system :

- maybe in Brake Drawer (BD)
- maybe in Slide Standard (SS)
- may be both at the same time.

What leads to the following optional function

$$\left\{ \begin{array}{l} F_{FD\_OS} : \textit{Face drawer opening system} \\ \textit{option}_{FD\_OS} \in \{BD\_BD, BD\_SS, BD\_BD \& BD\_SS\} \end{array} \right.$$



# Application to a industrial case study



- Outline
- Problematic
- Product Family
- Modeling using graph grammar
- Modeling using matrix transformations
- Conclusion and prospect

## Definition of productions

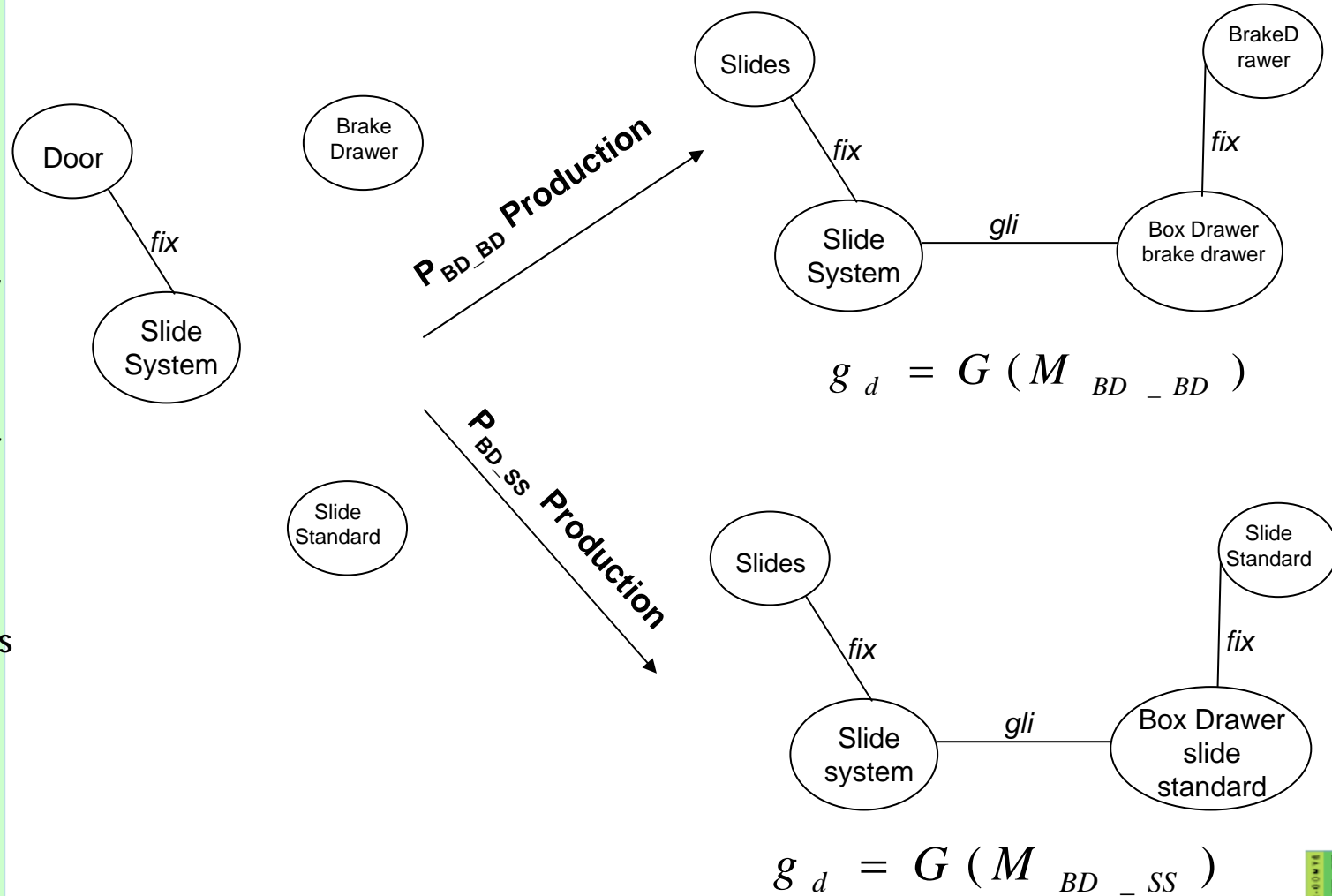



# Application to a industrial case study



Outline

Problematic

Product Family

Modeling using graph grammar

Modeling using matrix transformations

Conclusion and prospect

## Control Diagram

$$\begin{cases} P_{BD\_BD} = (att((M_{BD\_BD}), \pi = (\alpha(F_{FD\_OS}) \in \{\{BD\_BD\}, \{BD\_BD \& BD\_SS\}\}))) \\ P_{BD\_SS} = (att((M_{BD\_SS}), \pi = (\alpha(F_{FD\_OS}) \in \{\{BD\_SS\}, \{BD\_SS \& BD\_BD\}\}))) \end{cases}$$

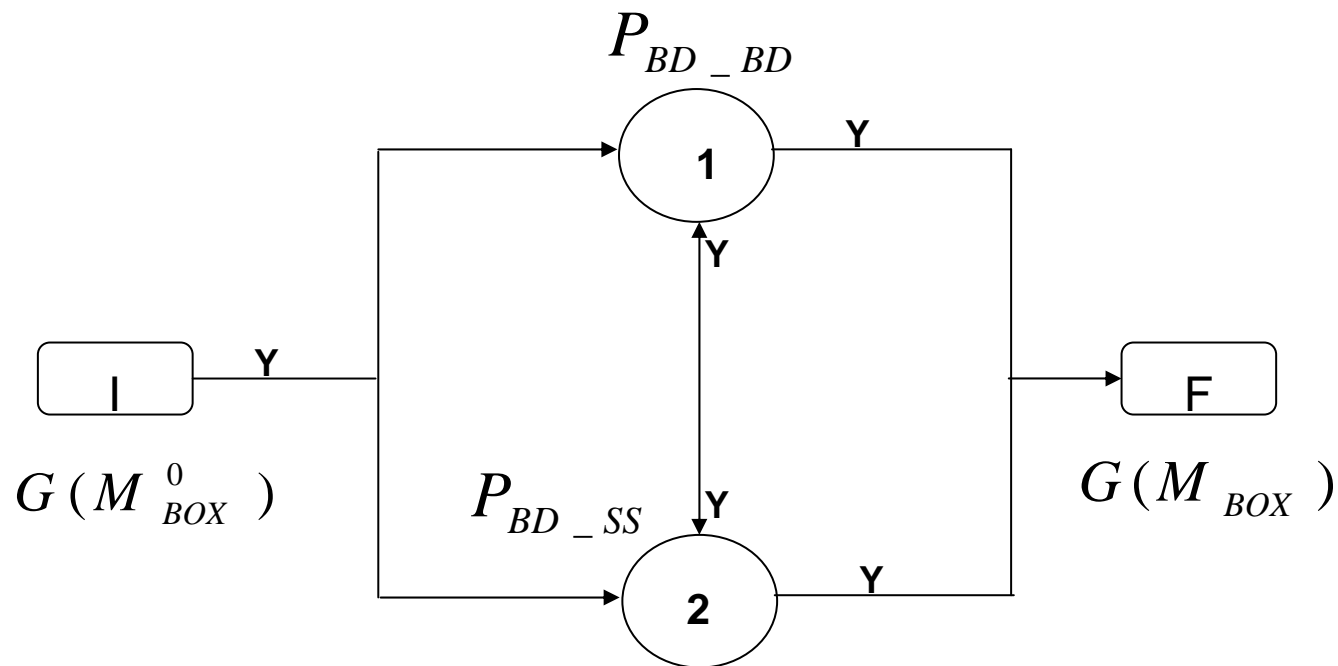



# Flow chart of variant derivation through multiple level graph rewriting



- Outline
- Problematic
- Product Family
- Modeling using graph grammar
- Modeling using matrix transformations
- Conclusion and prospect

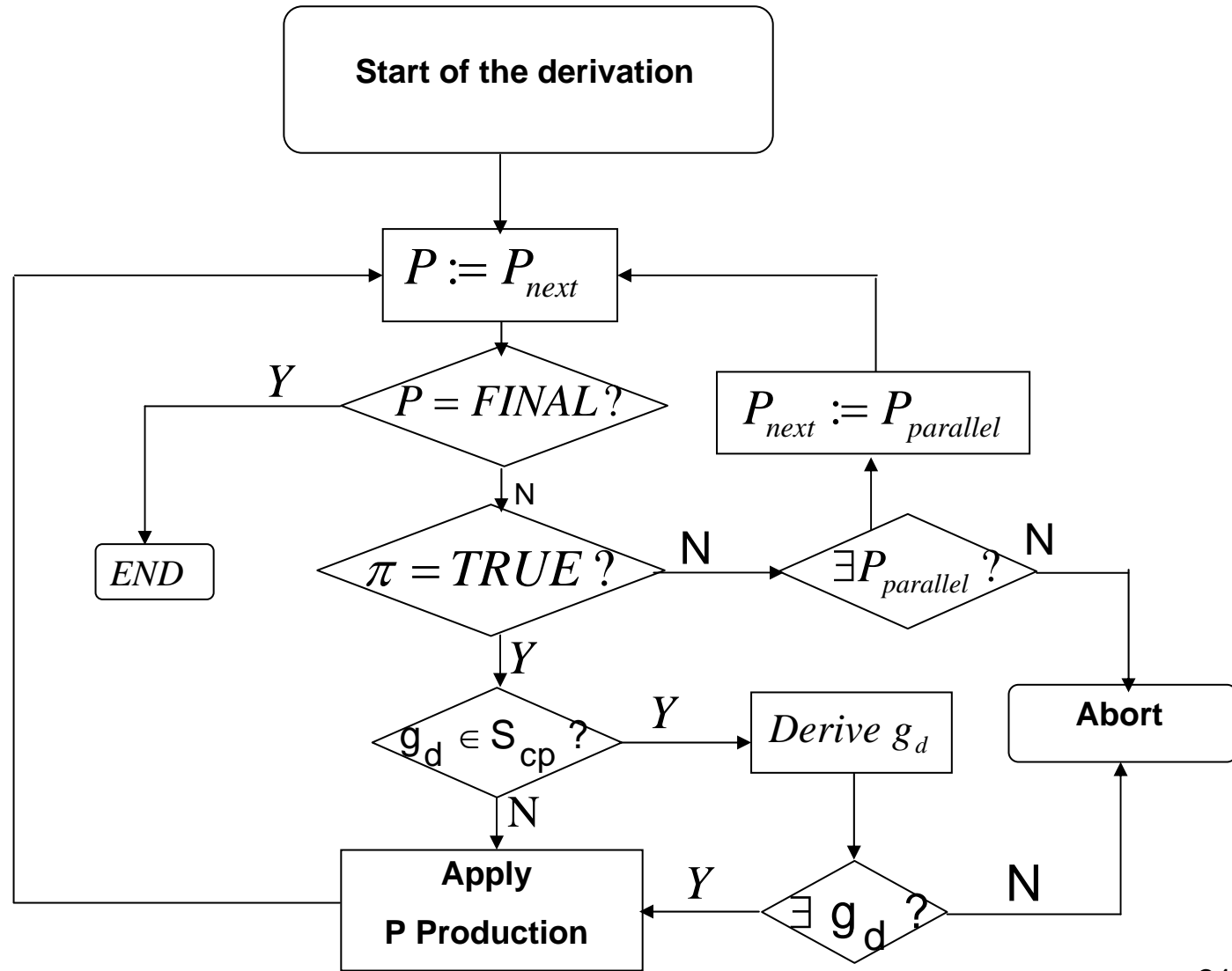



Outline

Problematic

Product Family

 Modeling using graph grammar

Modeling using matrix transformations

Conclusion and prospect

## Graph Grammars allow:

**-A good visual representation**

**-Formal definitions of the internal structure of Products family**

## The use of mathematical formulations allows:

**-A precise and clear definition of the acceptable combinations**

**However the response of the passage of the functional domain to the organic domain still deserves to be specified.**



### Design step

Customers needs



Offer new products

### Our step

Outline

Problematic

Product Family

Modeling using graph grammar

Modeling using matrix transformations

Conclusion and prospect

**Functional Analysis**

**Structural Analysis**

**Matrix Representation**

**Application to a family of vehicle wheels**



# Application to a family of vehicle wheels

- Outline
- Problematic
- Product Family
- Modeling using graph grammar
- Modeling using matrix transformations
- Conclusion and prospect



Tire



Wheel + Tire

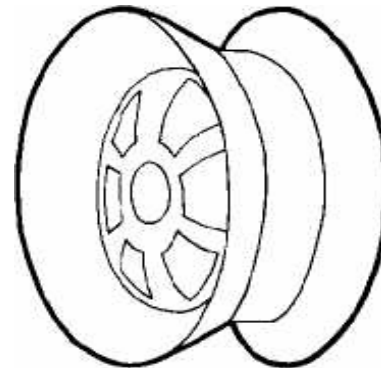

Wheel

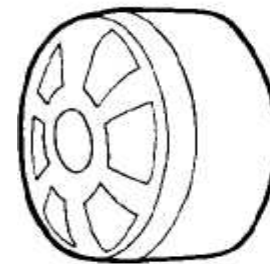

Wheel Disc

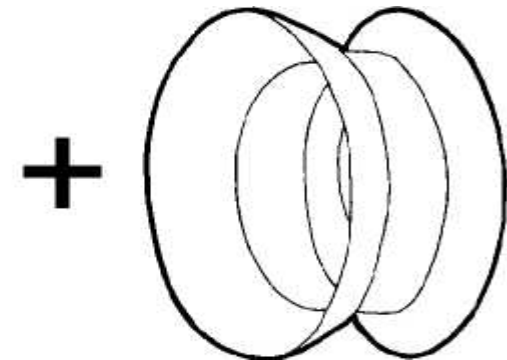

Rim



# Functional Analysis



## Relations of membership between functions

**Abstract or generic function**

**Elementary function**

**We can now establish a typology of the functions in the setting of the product family, that allows us to distinguish three types of functions**

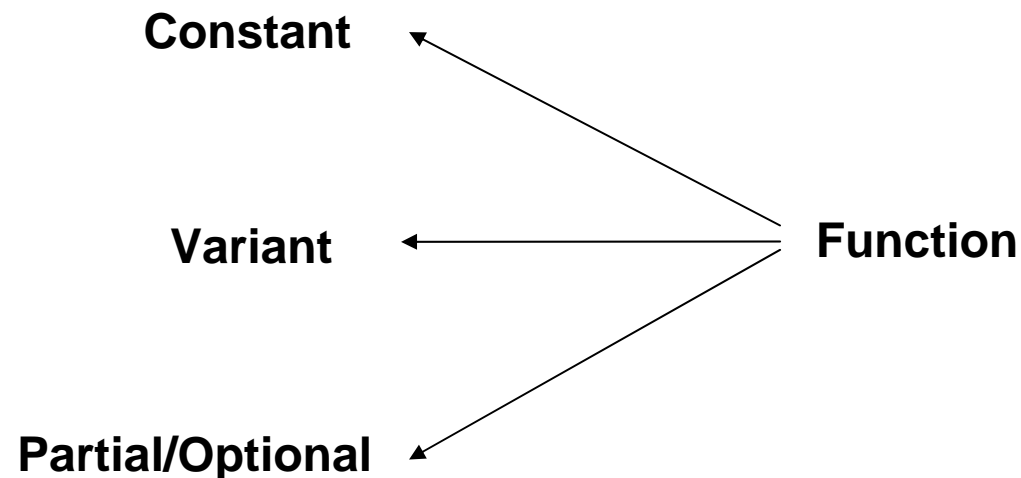

- Outline
- Problematic
- Product Family
- Modeling using graph grammar
- Modeling using matrix transformations
- Conclusion and prospect



# Functional Description of a car wheel family



Outline

Problematic

Product Family

Modeling using graph grammar

Modeling using matrix transformations

Conclusion and prospect

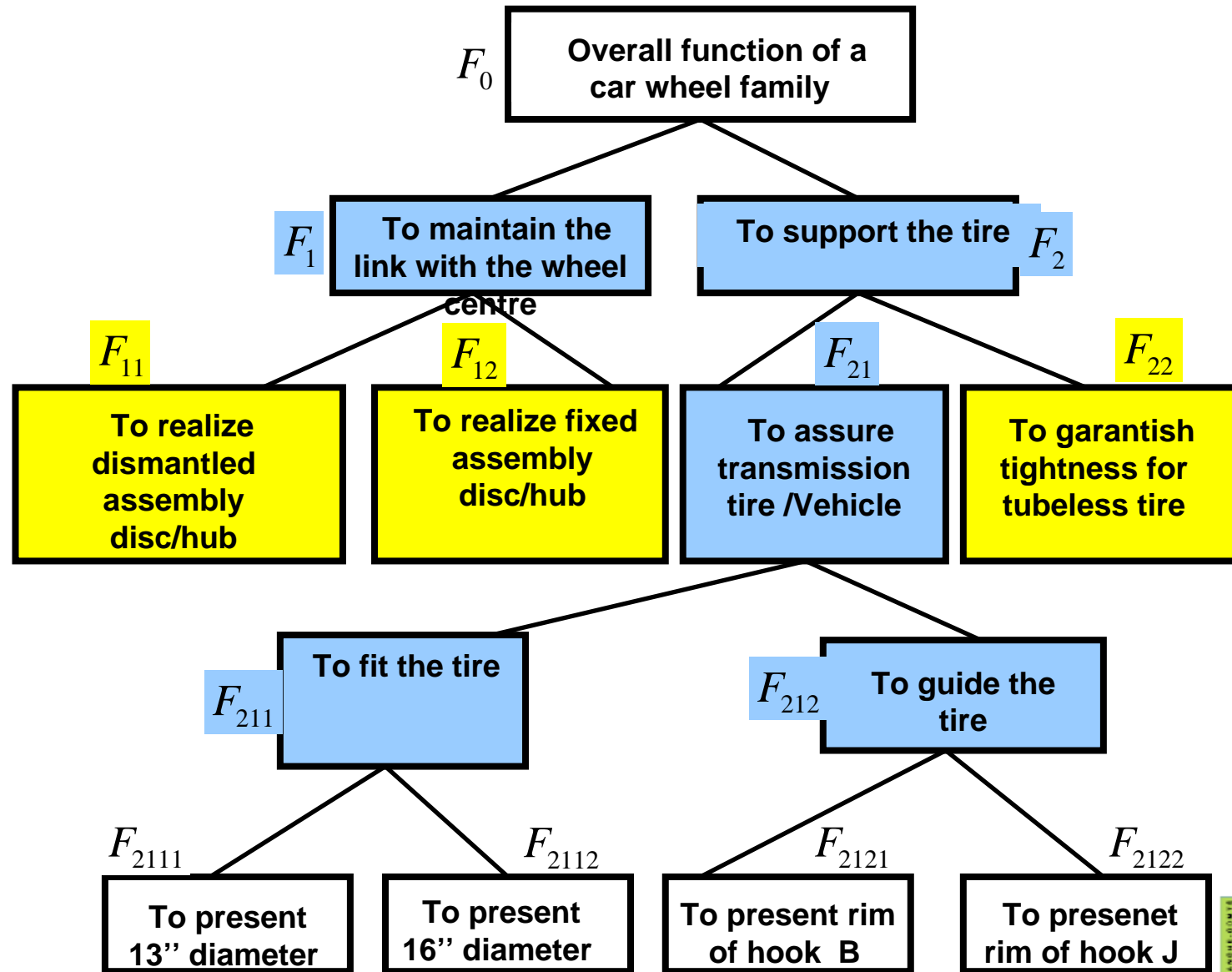



# Structural Analysis



Outline

Problematic

Product Family

Modeling using graph grammar

Modeling using matrix transformations

Conclusion and prospect

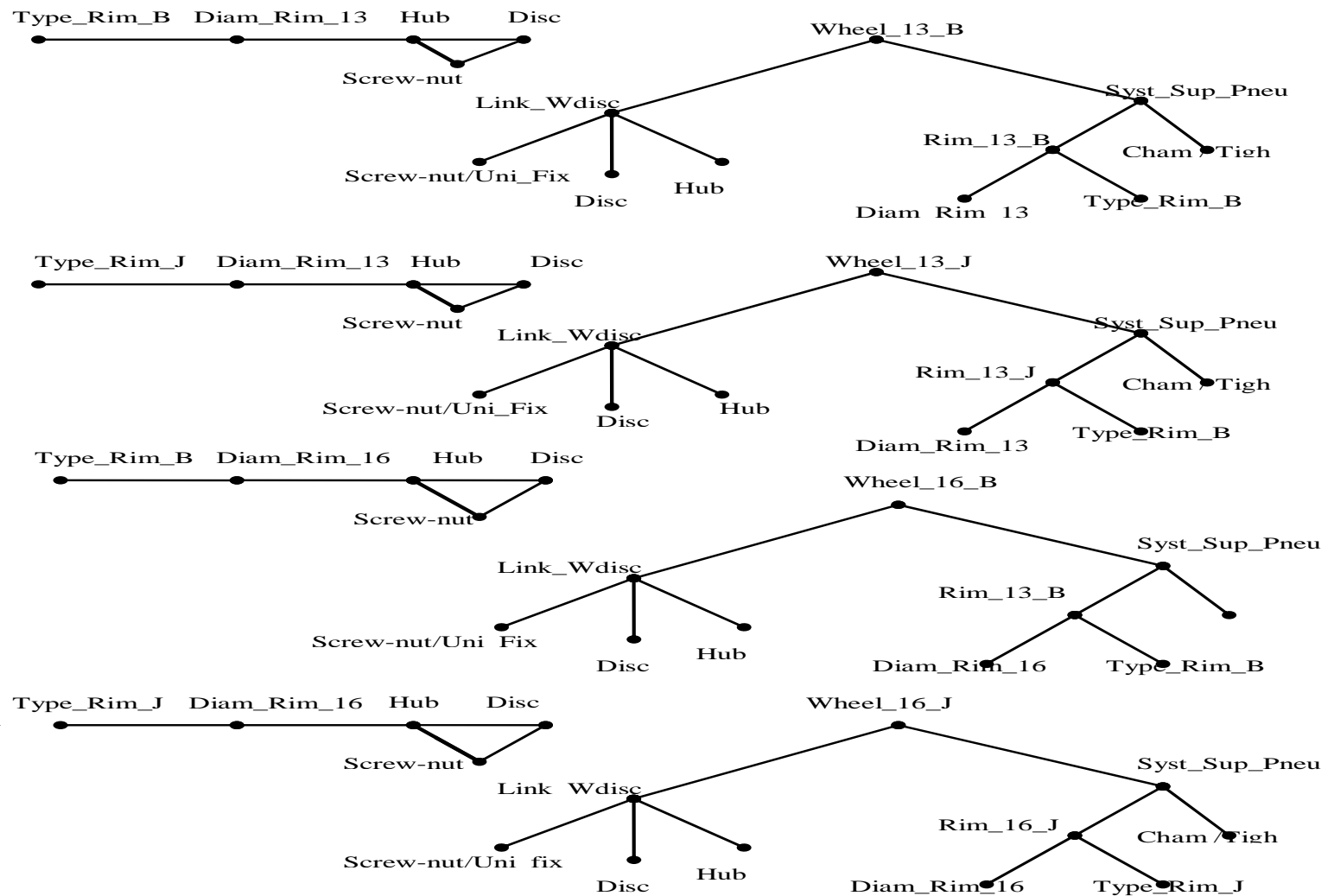



# Analysis and constitution of the classes of equivalences of a family of car wheels

Outline

$$Cl_1 = \{Roue\_13\_B, Roue\_13\_J, Roue\_16\_B, Roue\_16\_J\} \rightarrow F_0$$

Problematic

$$Cl_2 = \{Sys\_Sup\_Pneu\} \rightarrow F_2 \quad Cl_3 = \{Cham/ Etan\} \rightarrow F_{22}$$

Product Family

$$Cl_4 = \{Jante\_13\_B, Jante\_13\_J, Jante\_16\_B, Jante\_16\_J\} \rightarrow F_{21}$$

Modeling using graph grammar

$$Cl_5 = \{Diam\_Jante\_13, Diam\_Jante\_16\} \rightarrow F_{211}$$

$$Cl_6 = \{Diam\_Jante\_13\} \rightarrow F_{2111} \quad Cl_7 = \{Diam\_Jante\_16\} \rightarrow F_{2112}$$

Modeling using matrix transformations

$$Cl_8 = \{Type\_Jante\_B, Type\_Jante\_J\} \rightarrow F_{2121} \quad Cl_9 = \{Type\_Jante\_B\} \rightarrow F_{2122}$$

$$Cl_{10} = \{Type\_Jante\_J\} \rightarrow F_{212} \quad Cl_{11} = \{Liai\_voile\} \rightarrow F_1$$

Conclusion and prospect

$$Cl_{12} = \{Fix\_Uni, Disque, Moyeu\} \rightarrow F_{11} \quad Cl_{13} = \{Vis\_ecrou, Disque, Moyeu\} \rightarrow F_{12}$$





- Outline
- Problematic
- Product Family
- Modeling using graph grammar
- Modeling using matrix transformations**
- Conclusion and prospect

$$\begin{bmatrix} M_1 & & & & \\ & M_2 & & & \\ & & M_3 & & \\ & & & \dots & \\ & & & & M_{13} \end{bmatrix} \begin{bmatrix} Cl_1 \\ Cl_2 \\ Cl_3 \\ \dots \\ Cl_{13} \end{bmatrix} \cong \begin{bmatrix} F_0 \\ F_2 \\ F_{22} \\ \dots \\ F_{12} \end{bmatrix}$$

$$M_{F/C} = \begin{bmatrix} M_1 & & & & \\ & M_2 & & & \\ & & M_3 & & \\ & & & \dots & \\ & & & & M_{13} \end{bmatrix}$$

$$\begin{bmatrix} Roue\_13\_B \\ Roue\_13\_J \\ Roue\_16\_B \\ Roue\_16\_J \end{bmatrix}$$

$$Cl_1(M_1) \rightarrow F_0$$

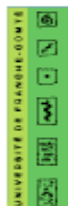



# Instantiation of generic components by classe of equivalence



- Outline
- Problematic
- Product Family
- Modeling using graph grammar
- Modeling using matrix transformations
- Conclusion and prospect

$$ROUE = M_1 \in \begin{bmatrix} Roue\_13\_B \\ Roue\_13\_J \\ Roue\_16\_B \\ Roue\_16\_J \end{bmatrix} \rightarrow Cl_1 \quad SYS\_SUP = M_2 = [Sys\_Sup\_Pneu] \rightarrow Cl_2$$

$$CHAM\_ETAN = M_3 = [Cham/Etan] \rightarrow Cl_3 \quad JANTE = M_4 \in \begin{bmatrix} Jante\_13\_B \\ Jante\_13\_J \\ Jante\_16\_B \\ Jante\_16\_J \end{bmatrix} \rightarrow Cl_4$$

$$DIAM = M_5 \in \begin{bmatrix} Diam\_Jante\_13 \\ Diam\_Jante\_16 \end{bmatrix} \rightarrow Cl_5 \quad DIAM\_13 = M_6 = [Diam\_Jante\_13] \rightarrow Cl_6$$

$$DIAM\_16 = M_7 = [Diam\_Jante\_16] \rightarrow Cl_7 \quad JANTE = M_8 \in \begin{bmatrix} Type\_Jante\_B \\ Type\_Jante\_J \end{bmatrix} \rightarrow Cl_8$$

$$CROCHET\_B = M_9 = [Type\_Jante\_B] \rightarrow Cl_9 \quad CROCHET\_J = M_{10} = [Type\_Jante\_J] \rightarrow Cl_{10}$$

$$LIAI\_VOILE = M_{11} = [Liai\_voile] \rightarrow Cl_{11} \quad FIX\_UNI = M_{12} \in \begin{bmatrix} Fix\_Uni \\ Disque \\ Moyeu \end{bmatrix} \rightarrow Cl_{12}$$

$$VIS\_ECROU = M_{13} \in \begin{bmatrix} Vis\_ecrou \\ Disque \\ Moyeu \end{bmatrix} \rightarrow Cl_{13}$$





# Generic Nomenclature

Ouline

Problematic

Product Family

Modeling using graph grammar

Modeling using matrix transformations

Conclusion and prospect

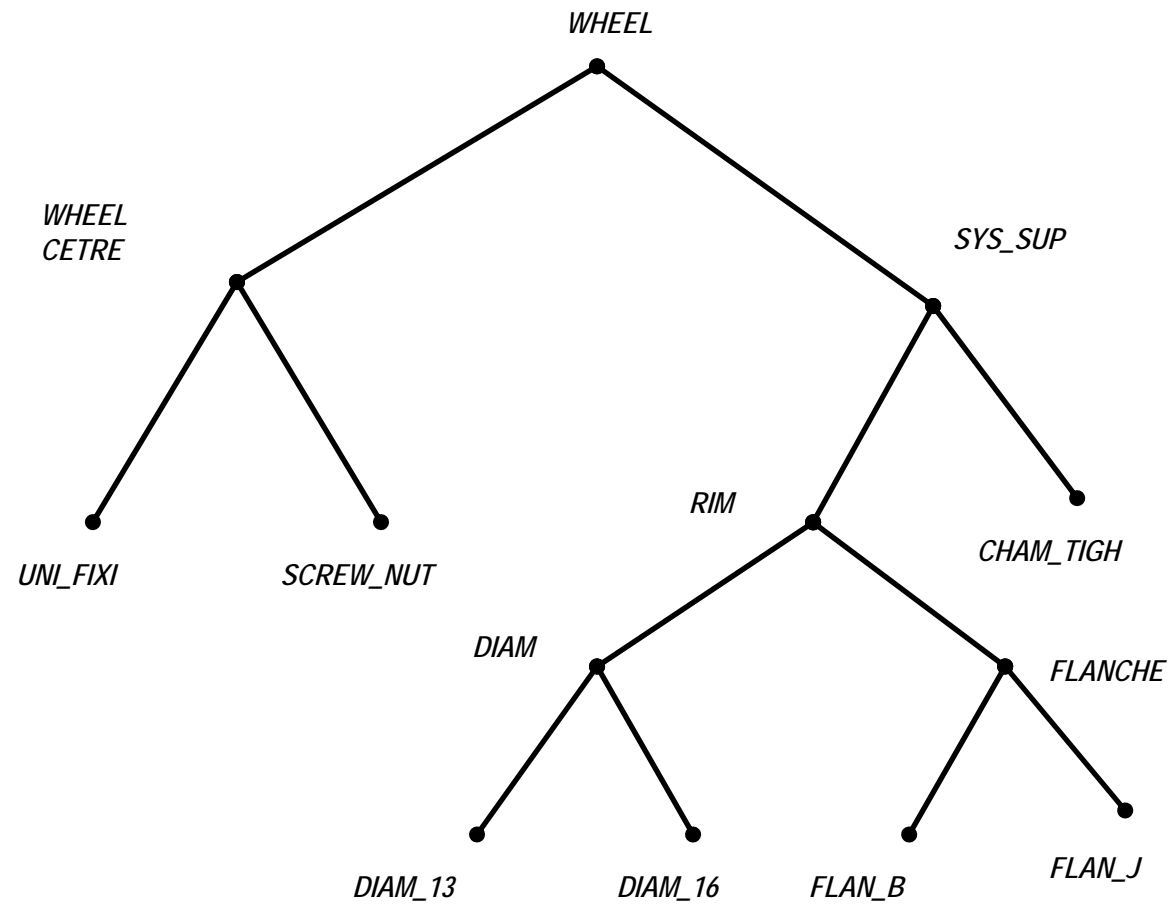



## Regrouping by blocks or modules and typology of the components

Outline

Problematic

Product Family

Modeling using graph grammar

 Modeling using matrix transformations

Conclusion and prospect

$ROUE \leftarrow \{LIAI\_VOILE, \quad SYS\_SUP\}$

$LIAI\_VOILE \leftarrow \{VIS\_ECROU, \quad FIX\_UNI\}$

$SYS\_SUP \leftarrow \{JANTE, \quad CHAM/ETAN\}$

$JANTE \leftarrow \{DIAM, \quad CROCHET\}$

$DIAM \leftarrow \{DIAM\_13, \quad DIAM\_16\}$

$CROCHET \leftarrow \{CROCHET\_B, \quad CROCHET\_J\}$

Constant Generic Component (CGC)

Variant Generic Component (CGV)

Partial Generic Component (CGP)



# Matrix Transformations

- Outline
- Problematic
- Product Family
- Modeling using graph grammar
- Modeling using matrix transformations**
- Conclusion and prospect

$M_{T/CGC}$

$M_{T/CGV}$

$M_{T/CGP}$

|              |            |              |
|--------------|------------|--------------|
| VIS<br>ECROU |            |              |
|              | FIX<br>UNI |              |
|              |            | CHAM<br>ETAN |

$$\begin{bmatrix} Cl_{13} \\ Cl_{12} \\ Cl_3 \end{bmatrix} \cong \begin{bmatrix} F_{12} \\ F_{11} \\ F_{22} \end{bmatrix}$$

$M_{T/CGC} =$

|              |            |              |
|--------------|------------|--------------|
| VIS<br>ECROU |            |              |
|              | FIX<br>UNI |              |
|              |            | CHAM<br>ETAN |



# Matrix Transformations



Ouline

Problematic

Product Family

Modeling using graph grammar

Modeling using matrix transformations

Conclusion and prospect

$M_{T/CGC}$

$M_{T/CGV}$

$M_{T/CGP}$

|      |            |         |       |      |         |
|------|------------|---------|-------|------|---------|
| ROUE |            |         |       |      |         |
|      | LIAI VOILE |         |       |      |         |
|      |            | SYS SUP |       |      |         |
|      |            |         | JANTE |      |         |
|      |            |         |       | DIAM |         |
|      |            |         |       |      | CROCHET |

$[Cl_{CGV}] \cong$

|           |
|-----------|
| $F_0$     |
| $F_1$     |
| $F_2$     |
| $F_{21}$  |
| $F_{211}$ |
| $F_{212}$ |

|         |         |           |           |           |         |
|---------|---------|-----------|-----------|-----------|---------|
| DIA M13 |         |           |           |           |         |
|         | DIAM 16 |           |           |           |         |
|         |         | CROCHET B |           |           |         |
|         |         |           | CROCHET J |           |         |
|         |         |           |           | VIS EYROU |         |
|         |         |           |           |           | FIX UNI |

$[Cl_{CGP}] \cong$

|            |
|------------|
| $F_{2111}$ |
| $F_{212}$  |
| $F_{2121}$ |
| $F_{2122}$ |
| $F_{21}$   |
| $F_{11}$   |



# Conclusion and Prospect



As observed in the case study, the advantages of graph grammar based approach include

Outline

Problematic



**Visual representation.** Graphical representations make the internal data structure of a product family explicit and easy to understand

Product Family



**Formal definition.** Using a mathematical language, all permissible manipulations are defined precisely and unambiguously. A complete space of design alternatives is articulated in a succinct manner

Modeling using graph grammar

Modeling using matrix transformations



**Ease of computational implementation.** Owing to the formal representation, product family design is transformed to a computational and direct production process of product variant

Conclusion and prospect



**Extensibility.** News productions can be easily defined for extra manipulation of modules. In addition, the importance of understanding the product family from an architectural perspective has been realized.





# Conclusion and Prospect



## In the two models

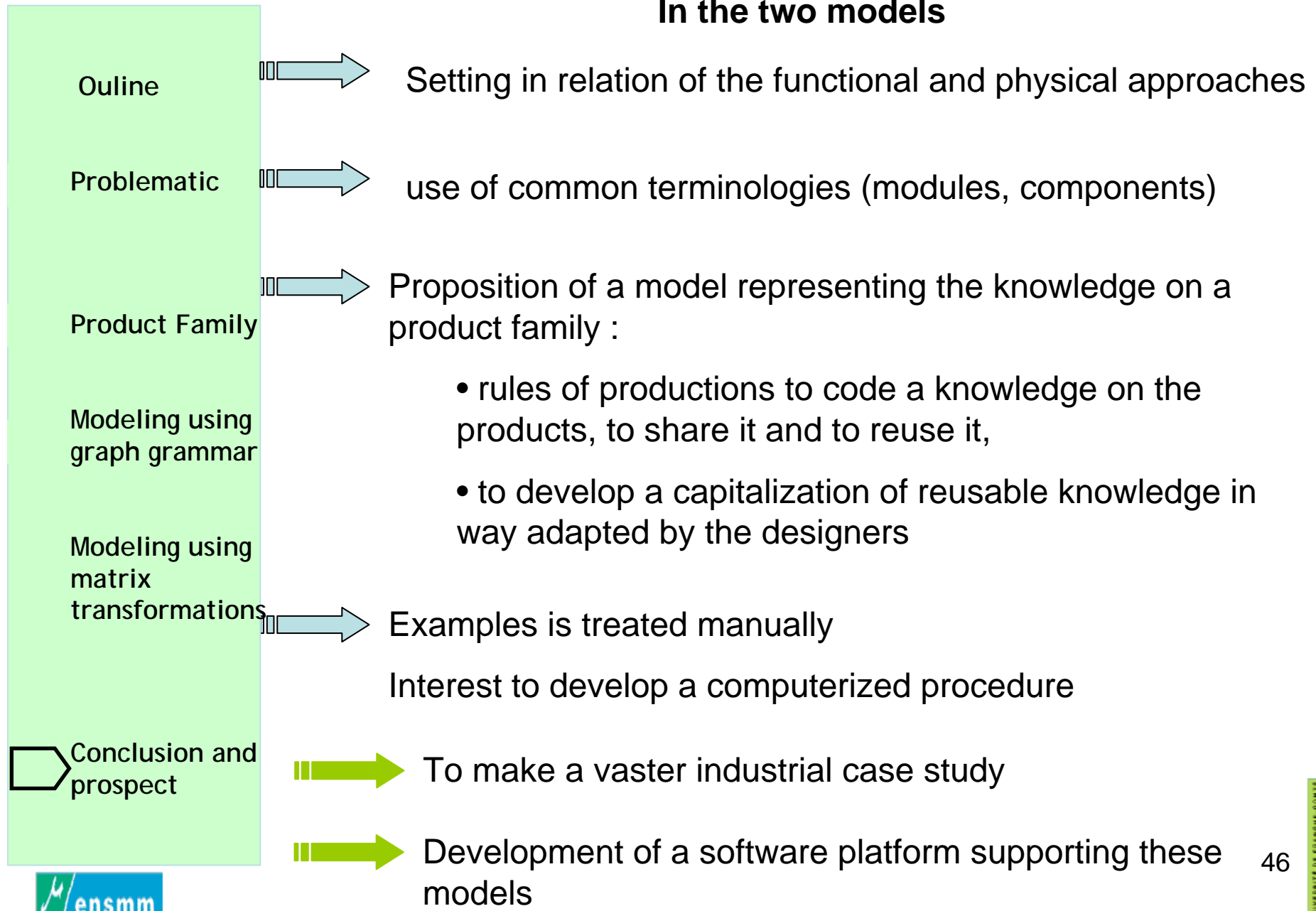



Outline

Problematic

Product Family

Modeling using  
graph grammar

Modeling using  
matrix  
transformations

 Conclusion and  
prospect

# Thank you for your Attention !